











# Operating Instructions

Audio



Mercedes-Benz

## Symbols

-  Warning
-  Environmental note
-  Possible damage to the vehicle
-  Tip
-  Instruction
-  Continuation symbol
-  Page reference
-  Image in the display

## Publication details

### Internet

Further information about Mercedes-Benz vehicles and about Daimler AG can be found on the following websites

**<http://www.mercedes-benz.com>**

**<http://www.daimler.com>**

### Editorial office

You are welcome to forward any questions or suggestions you may have regarding this manual to the technical documentation team at the following address:

Daimler AG, HPC: R822, D-70546 Stuttgart, Germany

Not to be reprinted, translated or otherwise reproduced, in whole or in part, without written permission of Daimler AG.

## **Welcome to the world of Mercedes-Benz.**

First of all, familiarize yourself with your audio equipment and read the operating instructions, especially the safety and warning notes, before operating the audio equipment. This will help you to obtain the maximum use from the system and avoid endangering yourself and others.

Depending on the model and equipment level, the functions of your audio equipment may deviate from certain descriptions and illustrations.

Mercedes-Benz is constantly updating its audio equipment to the state of the art and therefore reserves the right to introduce changes in design, equipment and technical features at any time.

You cannot, therefore, base any claims on the data, illustrations or descriptions in this manual.

Please consult an authorized Mercedes-Benz Center should you have any questions.

This manual is an integral part of the vehicle. You should always keep it in the vehicle and pass it on to the new owner if you sell the vehicle.

The technical documentation team at Daimler AG wishes you safe and pleasant motoring.



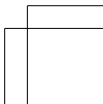
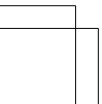
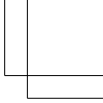
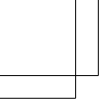

<b>Index</b> .....	<b>4</b>	<b>At a glance</b> .....	<b>11</b>
<b>Introduction</b> .....	<b>8</b>	<b>System settings</b> .....	<b>29</b>
		<b>Vehicle functions</b> .....	<b>35</b>
		<b>Navigation</b> .....	<b>39</b>
		<b>Telephone</b> .....	<b>41</b>
		<b>Audio</b> .....	<b>61</b>
		<b>Rear Seat Entertainment</b> .....	<b>89</b>

## 1, 2, 3 ...

911 emergency call ..... 43

## A

**Active partition (USB devices only)**

Selecting ..... 74

**Adjusting the bass** ..... 21

**Adjusting the volume** ..... 21

**Alphabetical track selection** ..... 86

**Audio AUX** ..... 88

**Audio CD/DVD or MP3 mode**

Switching to (Rear Seat Entertainment System) ..... 94

**Audio CD/MP3 mode**

Switching to ..... 71

**Audio DVD**

Pause function ..... 97

Stop function ..... 97

**Audio fadeout** ..... 40

**Audio format**

Setting (audio DVD mode) ..... 97

**AUX** ..... 87

**AUX (Rear Seat Entertainment System)**

Connecting ..... 103

Switching to ..... 104

**AUX jacks**

CD/DVD drive ..... 26

**AUX mode**

Setting the brightness/contrast/color ..... 104

Switching picture format ..... 104

## B

**Basic functions** ..... 20

**Basic menu**

Calling up ..... 18

**Becker® MAP PILOT**

see Navigation

**Bluetooth®**

Activating/deactivating ..... 33

Connecting another mobile phone ... 47

Device list ..... 78

Searching for a mobile phone ..... 44

Settings ..... 32

**Bluetooth® audio basic display** ..... 80

**Bluetooth® audio device**

Connecting ..... 77

Reconnecting ..... 79

**Bluetooth® audio mode**

Switching on ..... 80

**Bluetooth® interface**

Telephony ..... 43

**Bluetooth® interface telephony**

Conditions ..... 43

## C

**Call lists** ..... 56

Opening and selecting an entry ..... 57

**Camera**

see Rear view camera

**Category**

Satellite radio ..... 68

**CD**

Ejecting ..... 71

Fast forward/fast rewind ..... 74

Inserting ..... 71

Mode, switching to ..... 71

Multisession ..... 75

Selecting a track ..... 73

**CD/DVD**

Ejecting (Rear Seat Entertainment System) ..... 94

Inserting (Rear Seat Entertainment System) ..... 93

**CD mode** ..... 70

Pause function ..... 72

Playback options ..... 75

Selecting a medium ..... 72

**Connecting an iPod®/iPhone®** ..... 82

**Connecting a USB device** ..... 71

**Contacts**

Deleting ..... 55

Hiding data ..... 56

Importing ..... 55

**Controller** ..... 14

**Control menu**

Showing/hiding ..... 99

**Control panel**

Audio 20 ..... 13

**Correct use** ..... 8

**D****Data medium**

- MP3 ..... 75
- Video DVD ..... 98

**Display** ..... 16

- Adjusting the brightness ..... 31
- Selecting the design ..... 31

**E****External audio source (AUX)** ..... 87**External devices (Media Interface)**

- Connecting ..... 83

**F****Fast forward/rewind** ..... 96**Favorites button** ..... 32**Folders**

- Selecting (MP3 mode) ..... 74

**Function restrictions**

- Telephone operation ..... 43
- Video DVD mode ..... 92

**I****Indicator lamp**

- Remote control ..... 27

**Inserting/removing CDs**

- Single CD drive ..... 71

**L****Lumbar support** ..... 36**M****Media Interface**

- Activating ..... 84
- Active partition ..... 74
- Connection options ..... 82
- iPod®/iPhone® ..... 82
- Mode ..... 82
- Playback options ..... 87
- Selecting categories ..... 85
- Selecting folders ..... 85
- Selecting music files ..... 85
- Selecting playlists ..... 85

**Media list** ..... 72**Menu**

- Overview ..... 17
- Showing/hiding ..... 99

**Menu system** ..... 18**Mobile phone**

- Connecting (Bluetooth® interface) ... 44
- De-authorizing ..... 47
- External authorization ..... 46
- Registering (authorizing) ..... 45

**MP3**

- Bit/sampling rates ..... 76
- Copyright ..... 76
- Data medium ..... 75
- File systems ..... 75
- Formats ..... 76
- Operation ..... 70
- Selecting a medium ..... 72

**MP3 mode**

- Selecting a folder ..... 96

**Multifunction steering wheel** ..... 18**Multisession CDs** ..... 75**N****Navigation**

- Becker® MAP PILOT ..... 40
- Moving the map ..... 40

**O****Operating system**

- Audio 20 ..... 12

**Operation**

- Example ..... 20

**P****Passcode**

- Entering ..... 45

**Phone book** ..... 52

- Icon overview ..... 54
- Receiving vCards ..... 52

**Playback options** ..... 97**R****Radio**

- Autostore ..... 65
- Entering a frequency ..... 64

- Overview ..... 62
- Preset memory ..... 64
- Searching for a station ..... 63
- Selecting a station ..... 63
- Storing stations automatically ..... 65
- Storing stations manually ..... 64
- Switching HD Radio on/off ..... 62
- Switching wavebands ..... 63
- Radio mode**
- Switching to ..... 62
- Rear-compartment screens** ..... 24
- Rear Seat Entertainment System**
- Adjusting sound settings ..... 91
- AUX mode ..... 103
- CD/DVD audio and MP3 mode ..... 93
- Changing the batteries ..... 90
- Components ..... 24
- Cordless headphones ..... 27
- Hiding/showing the picture ..... 93
- Multiple users ..... 92
- Operating with the headphones ..... 91
- Remote control ..... 25
- Safety notes ..... 93
- Selecting the display language ..... 92
- Setting the brightness ..... 93
- Switching the display design ..... 93
- System settings ..... 92
- Video DVD mode ..... 98
- Rear view camera** ..... 38
- Redial** ..... 51
- Remote control**
- Switching SmartKey illumination on/off ..... 25
- S**
- Safety notes**
- Audio CD and MP3 mode ..... 70
- Operating safety ..... 8
- SatRadio** ..... 66
- Displaying information ..... 69
- Registering ..... 67
- Selecting a category ..... 68
- Switching to ..... 67
- Screen**
- Selecting for remote operation ..... 25
- Switching on/off (Rear Seat Entertainment System) ..... 25
- Seats**
- Adjusting the 4-way lumbar support ..... 36
- Massage function ..... 37
- Multicontour seat ..... 36
- Resetting settings ..... 37
- Single call**
- Functions ..... 52
- Sound**
- Balance/fader ..... 22
- Setting balance ..... 22
- Switching on/off ..... 21
- Sound settings** ..... 21
- Speed dial list**
- Storing a phone book entry in the speed dial list ..... 58
- Surround sound** ..... 22
- Surround sound (harman/kardon® surround sound system)**
- Notes ..... 22
- Switching on/off ..... 22
- Switching HD Radio on/off**
- see Radio
- Switching off** ..... 21
- Switching on** ..... 20
- System settings**
- Date ..... 31
- Display ..... 31
- Language ..... 33
- Reset ..... 33
- Time ..... 31
- T**
- Telephone**
- Accepting/ending a call ..... 49
- Ending an active call ..... 51
- Incoming call ..... 49
- Making a call via speed dial ..... 51
- Operating options ..... 42
- Outgoing call ..... 50
- Sending DTMF tones ..... 52
- Switching the hands-free microphone on/off ..... 52
- Telephone basic menu**
- Bluetooth® interface ..... 48

<b>Telephone book</b>	
Calling up .....	54
Importing external data .....	52
Multifunction steering wheel .....	55
<b>Telephone mode</b>	
Redialing .....	51
<b>Text messages (SMS)</b> .....	59
Calling the sender .....	60
Deleting .....	60
Inbox .....	59
Information and requirements .....	59
Reading .....	60
<b>Time</b>	
Setting the time .....	31
<b>Track</b>	
Selecting .....	95
<b>Treble</b>	
Setting .....	21

## U

<b>Using the telephone</b> .....	49
----------------------------------	----

## V

<b>Vehicle</b>	
Data acquisition .....	9
<b>Video DVD</b>	
DVD menu .....	101
Fast forward/rewind .....	100
Function restrictions .....	98
Interactive content .....	103
Pause function .....	100
Picture settings .....	101
Selecting a film/title .....	100
Selecting a scene/chapter .....	100
Setting the language .....	102
Stop function .....	100
Subtitles .....	103
<b>Video DVD mode</b>	
DVD playback restrictions .....	98
Switching to .....	99
<b>Volume</b>	
Adjusting (multifunction steering wheel) .....	18
Phone calls .....	21

## W

<b>Weather Band</b>	
Searching for a channel .....	65
Switching on .....	65



## Operating safety

### Important safety notes

#### WARNING

If you operate integrated communication equipment in the vehicle when driving, you will be distracted from traffic conditions. You could also lose control of the vehicle. There is a risk of an accident.

Only operate the equipment when the traffic situation permits. If you are not sure that this is possible, park the vehicle paying attention to traffic conditions and operate the equipment when the vehicle is stationary.

Bear in mind that at a speed of just 30 mph (approximately 50 km/h), your vehicle is covering a distance of 44 feet (approximately 14 m) every second.

#### WARNING

Change or modification not expressly approved by the party responsible for compliance could void the user's authority to operate this equipment.

**!** Note: This equipment has been tested and found to comply with the limits for a Class A digital device, pursuant to Part 15 of the FCC Rules. These limits are designed to provide reasonable protection against harmful interference when the equipment is operated in a commercial environment. This equipment generates, uses and can radiate radio frequency energy and, if not installed and used in accordance with the instruction manual, may cause harmful interference to radio communications.

This equipment complies with FCC radiation exposure limits set forth for uncontrolled equipment and meets the FCC radio frequency (RF) Exposure Guidelines in Supplement C to OET65.

This equipment has very low levels of RF energy that is deemed to comply without maximum permissive exposure evaluation (MPE). But it is desirable that it should be

installed and operated with at least 8 inches (20 cm) and more between the radiator and a person's body (excluding extremities: hands, wrists, feet and legs.)

### Correct use

Always observe the following when using the audio equipment:

- the safety notes in this manual
- national road traffic regulations

#### WARNING

Modifications to electronic components, their software as well as wiring can impair their function and/or the function of other networked components. In particular, systems relevant to safety could also be affected. As a result, these may no longer function as intended and/or jeopardize the operating safety of the vehicle. There is an increased risk of an accident and injury.

Never tamper with the wiring as well as electronic components or their software. You should have all work to electrical and electronic equipment carried out at a qualified specialist workshop.

**i** Roof antenna functionality (telephone, satellite radio, GPS) can be affected by the use of roof carrier systems.

Retrofitting metalized plastic films to the windows can affect radio reception and lead to poorer reception of all other antennas (e.g. emergency call antennas) inside the vehicle.

**i** **Protection against theft:** this device is equipped with technical provisions to protect it against theft. Further information on protection against theft can be obtained from an authorized Mercedes-Benz Center.

## Declarations of conformity

### Vehicle components which receive and/or transmit radio waves

**USA:** "The wireless devices of this vehicle comply with Part 15 of the FCC Rules. Operation is subject to the following two conditions: 1) These devices may not cause harmful interference, and 2) These devices must accept any interference received, including interference that may cause undesired operation. Changes or modifications not expressly approved by the party responsible for compliance could void the user's authority to operate the equipment."

**Canada:** "The wireless devices of this vehicle comply with Industry Canada license-exempt RSS standard(s). Operation is subject to the following two conditions: (1) These devices may not cause interference, and (2) These devices must accept any interference, including interference that may cause undesired operation of the device."

## Audio system features

These Operating Instructions describe all standard and optional equipment available for your audio device at the time of going to print. Country-specific differences are possible. Please note that your audio equipment may not offer all the features described. This also applies to safety-relevant systems and functions. The equipment in your vehicle may therefore differ from that shown in the descriptions and illustrations. The original purchase agreement lists all systems installed in your vehicle. Contact an authorized Mercedes-Benz Center if you have any questions about equipment or operation.

## Function restrictions

For safety reasons, some Audio 20 functions are restricted or unavailable while the vehicle

is in motion. You will notice this, for example, because you will either not be able to select certain menu items or because Audio 20 will display a message to that effect.

## Data stored in the vehicle

A number of electronic components in your vehicle contain data memories.

These data memories temporarily or permanently store technical information about:

- The vehicle's operating state
- Incidents
- Malfunctions

This technical information generally documents the condition of a component, a module, a system or an environment.

These are, for example:

- operating conditions of system components. This includes, e.g. fluid levels.
- status messages from the vehicle and from individual vehicle components. This includes, e.g. number of wheel revolutions/speed, deceleration, lateral acceleration.
- malfunctions and defects in important system components. This includes, e.g. lights, brakes.
- reactions of the vehicle in special driving situations. This includes, e.g. deployment of an air bag, intervention of stability control systems.
- environmental conditions. This includes, e.g. the outside temperature.

This data is exclusively technical in nature and is used to:

- assist in the detection and rectification of malfunctions and defects
- optimize vehicle functions

The data cannot be used to trace the vehicle's movements over distances traveled.

When your vehicle is serviced, this technical information can be read out from the event and malfunction memory.

Services include:

- repairs
- service processes
- warranty claims
- quality assurance

The information is read out by authorized employees of the service network (including manufacturers) using special diagnostic devices. You can find more information there if necessary.

After a malfunction has been rectified, the information in the malfunction memory is deleted or consecutively overwritten.

In normal vehicle operation, situations may arise in which this technical data could become personal in nature in conjunction with other information and, if necessary, on consultation of an approval official.

Examples include:

- accident reports
- vehicle damage
- witness testimonies

Further additional features which are contractually agreed with the customer likewise allow specific vehicle data to be obtained from the vehicle. Such additional features include vehicle locating in an emergency, for example.

Audio 20 operating system .....	12
Multifunction steering wheel .....	18
Operating Audio 20 .....	18
Basic functions of Audio 20 .....	20
Rear Seat Entertainment .....	24

## Audio 20 operating system

## Overview



Example

	Function	Page
①	Display	16
②	Control panel with a single CD drive	13
③	Controller	14

## Audio 20 components

Audio 20 consists of:

- the control panel with a single CD drive
- the display
- the controller

In addition, Audio 20 can be operated via the multifunction steering wheel.

Audio 20 control panel

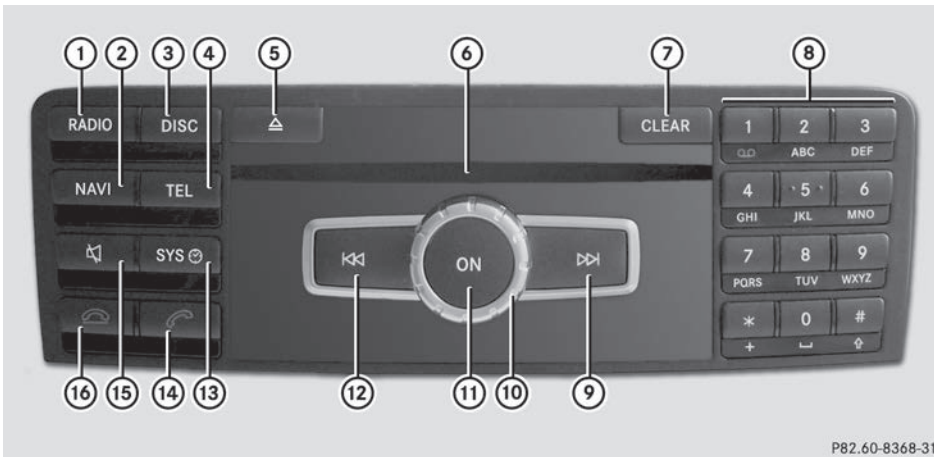



P82.60-8368-31

At a glance

	Function	Page
①	<b>RADIO</b> Switches to radio mode Switches wavebands Switches to SatRadio mode	62 63 66
②	<b>NAVI</b> Switches to navigation mode (only in conjunction with the navigation module)	40
③	<b>DISC</b> Switches to audio CD or MP3 mode	71
④	<b>TEL</b> Activates telephone mode	48
⑤	<b>Eject</b> Eject button	71
⑥	Disc slot Insert CDs Remove CDs	71 71
⑦	<b>CLEAR</b> Delete button • Deletes characters • Deletes an entry	

	Function	Page
⑧	Number pad • Selects stations via the station presets • Stores stations manually • Telephone number entry • Sends DTMF tones • Character entry	64 64 50 52
⑨	<b>Fast forward</b> Selects a station using the station search function Selects the next track Fast forward	63 73 74
⑩	Adjusts the volume	21
⑪	<b>ON</b> Switches Audio 20 on/off	20
⑫	<b>Previous track</b> Selects a station using the station search function Selects the previous track Rewinds	63 73 74
⑬	<b>SYS</b> Calls up the basic menu	17



	Function	Page
⑭	 Accepts a call	49
	Dialing a number	50
	Redials	51
⑮	 Mute	21
	Switches the hands-free system on/off	

	Function	Page
⑯	 Rejects a call	49
	Ends an active call	51

## Audio 20 controller

### Introduction

You can use the controller to select functions in the display. To do so, move the selection bar.



① Controller

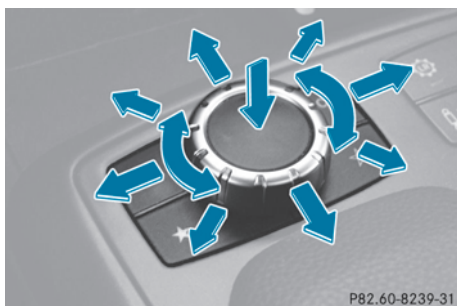

The controller can be:

- pressed briefly or pressed and held
- turned clockwise or counterclockwise
- slid to the left, to the right, up or down

In this way you can:

- scroll within menus
- select menu items
- exit menus

**i** If your vehicle is equipped with the Becker® MAP PILOT navigation module, you can slide the controller diagonally to move the map (> page 40).

## Overview

Symbol	Controller operation	Function (examples)
👉	Press briefly	<ul style="list-style-type: none"> <li>• Selects a menu item</li> </ul>
	Press and hold until the selected action is carried out	<ul style="list-style-type: none"> <li>• Stores a station</li> </ul>
⏪👉	Turn	<ul style="list-style-type: none"> <li>• Scrolls through vertical or horizontal menus</li> <li>• Scrolls through text</li> <li>• Makes settings</li> </ul>
↑👉↓	Slide	<ul style="list-style-type: none"> <li>• Scrolls through a vertical menu</li> <li>• Exits a horizontal menu</li> </ul>
←👉→	Slide	<ul style="list-style-type: none"> <li>• Scrolls through a horizontal menu</li> <li>• Exits a vertical menu</li> </ul>
	Slide and hold	<ul style="list-style-type: none"> <li>• Fast forward or rewind during CD playback</li> <li>• Scrolls through lists</li> </ul>

## Controller buttons

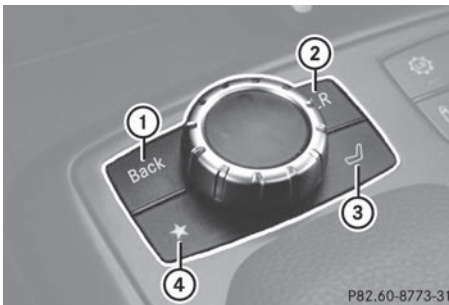

- ① Back button **BACK**
- ② Clear button **CLR**
- ③ Seat function button
- ④ Favorites button

**i** If the seats on your vehicle can be adjusted via Audio 20, it will have the seat function button. Otherwise, a second favorites button will be located here.

- ▶ **To go up a level in the menu:** briefly press the **BACK** back button  
Audio 20 changes to the next higher menu level in the current operating mode.
  - ▶ **To switch to the basic menu:** press and hold the **BACK** back button.  
Audio 20 changes to the basic menu of the current operating mode.
  - ▶ **To delete individual characters:** briefly press the **CLR** delete button.
  - ▶ **To delete an entire entry:** press and hold the **CLR** delete button.
  - ▶ **To call up the favorites function:** press the left or right star button.
- i** Information on setting the Favorites function (▶ page 32).

## Audio 20 display

### Display overview

The display shows the function currently selected and its associated menus. The display is divided into several areas.

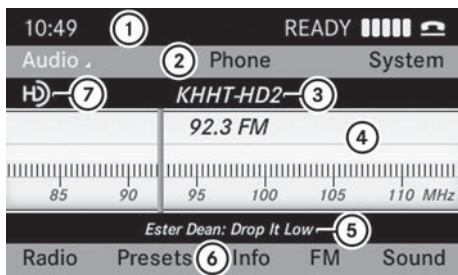

P82.60-8173-31

Example: radio



- ① Status bar
- ② Main function bar
- ③ Waveband/frequency
- ④ Display/selection window
- ⑤ Radio text plus (if available)
- ⑥ Submenu bar
- ⑦ HD Radio logo (only with HD Radio reception)

**i** The layout of the menus may vary, depending on the vehicle's equipment.

Depending on the current setting of Audio 20, the following information can be displayed in the status bar:





- Time

If a mobile phone is operational, additional information is shown:

- Name of the mobile phone network provider
- Signal strength of mobile phone network  (> page 48)
- Receiver icon ,  (> page 48)

## Menu overview

The main functions, i.e. radio mode, CD mode, telephone mode and systems settings, can be reached at the touch of a button. Each main function has a basic menu. Each item in the basic menu can have several submenu items.

Function button	Basic menu	Menu items
	Radio	Radio Presets Info FM/AM/WB Sound
	Disc	CD/MP3/USB/BT Audio <sup>1</sup> /Media Int. <sup>2</sup> Tracklist/folder Media Sound
	Telephone	Telephone Text messages Call lists
	System	Settings Time Display off

## Notes on cleaning

**!** When cleaning the display must be switched off and cooled down.

Please clean the display screen, when necessary, with a commercially available microfiber cloth and cleaning agent formulated for TFT/LCD displays. Then dry and polish the screen with a dry microfiber cloth.

**!** Avoid using alcoholic thinners, gasoline or abrasive cleaning agents. These products can damage the display surface.

<sup>1</sup> Bluetooth® audio.







<sup>2</sup> Media Interface.

## Multifunction steering wheel











P82.60-8240-31

Example illustration

	Function	Page
①	Multifunction display	
②	 Voice Control System - not installed	
③	 Increases the volume	21
	 Decreases the volume	21
	 Accepts a call	49
	 Ends a call	49
	 <b>Press briefly:</b> mutes the audio source	21

## Function

## Page

- ④   Calls up the menu bar and selects menus
-   **Press briefly:** selects a submenu or scrolls through lists. In the **Audio** menu, this selects a stored station or an audio track. In the **Phone** menu, this switches to the phone book and selects a name or phone number.
-   **Press and hold:** in the **Audio** menu, this selects the next/previous station or selects an audio track using rapid scrolling. In the **Phone** menu, this starts rapid scrolling through the phone book.
-  Confirms selections and fades out messages. In the **Phone** menu, this switches to the phone book and starts dialing.
- ⑤  **Press briefly:** returns to the previous menu and hides display messages
-  **Press and hold:** selects the standard display; see vehicle Operator's Manual

## Operating Audio 20

## Selecting menus

## Basic menu

- Press the appropriate **RADIO**, **DISC**, **TEL** or **sys** function button.

The basic menu of the respective function is shown. The main area is active.

The active area is highlighted.

- i** The following pictures show the display in daytime design (> page 31). The menu highlighting appearance is different depending on the display design.

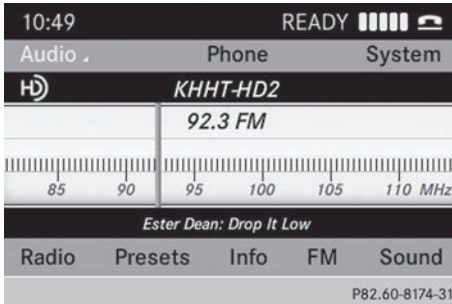

**Switching from the display window to the submenu bar**

- ▶ Slide the controller.

**Horizontal menus**



P82.60-8175-31

**Navigating within a menu**

- ▶ Slide or turn the controller. The menu item selected is highlighted in white.

**Selecting a menu item**

- ▶ Press the controller.

**Exiting a menu without making a selection**

- ▶ Slide the controller in the opposite direction to the direction of the list.
- or
- ▶ Press the **BACK** back button on the controller.

**Vertical menus**

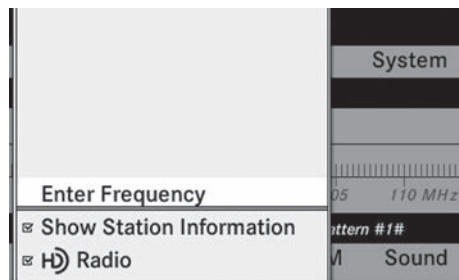

P82.60-8176-31

**Navigating within a menu**

- ▶ Slide or turn the controller. The menu item selected is highlighted in white.

**Selecting a menu item**

- ▶ Press the controller.

**Exiting a menu without making a selection**

- ▶ Slide the controller in the opposite direction to the direction of the list.
- or
- ▶ Press the **BACK** back button on the controller.



### Operating example

Example: setting the radio station to FM 104.6 MHz.

- ▶ Press the **RADIO** button once or several times until the **FM** waveband appears in the status bar.
- ▶ **To switch to the submenu bar:** slide the controller.
- ▶ **To highlight Radio in the submenu bar:** Slide or turn the controller.

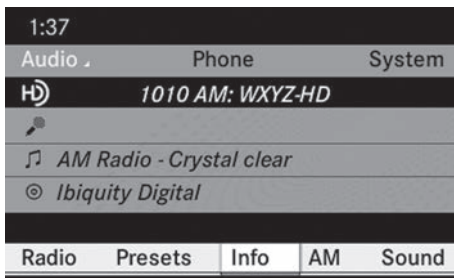

P82.60-8175-31

- ▶ **To confirm your selection:** press the controller.  
A selection list with the functions in the **Radio** submenu appears.

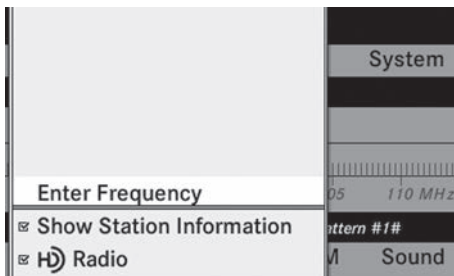

P82.60-8176-31

- ▶ **To highlight the Enter Frequency function:**  
Slide or turn the controller.
- ▶ **To confirm your selection:** press the controller.

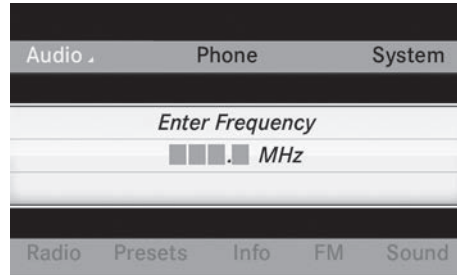

P82.60-8177-31

- ▶ Only permissible numbers for the frequency range can be entered in front of the decimal point. If non-permissible numbers are entered after the decimal point, the next lowest frequency is set.

- ▶ Press the number keys on the keypad.  
The station selected is played.

### Basic functions of Audio 20

#### Switching Audio 20 on/off

#### Overview

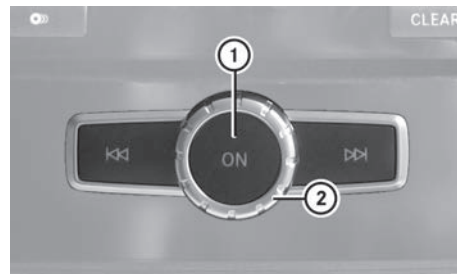

P82.60-8178-31

- ① Button **ON**
- ② Thumbwheel

#### Switching Audio 20 on

- ▶ Press the **ON** button.
- or
- ▶ If Audio 20 was on the last time the ignition was switched off, turn the SmartKey to position 2 in the ignition lock.

The last main function used is reactivated after switching on.

### Switching Audio 20 off

- ▶ Press the **ON** button.

or

- ▶ Turn the SmartKey to position 0 in the ignition lock and remove the SmartKey.

- i** If you switch off Audio 20, playback of the current audio source will also be switched off. Your mobile phone can also no longer be operated via the Audio 20 system.

### Switching the sound on or off

#### Switching the audio source on/off

- ▶ Press the **⏮** button.

The sound from the audio source is switched on or off.

- i** When the sound is switched off, you will see the **⏮** symbol in the status bar. If you change the audio source or adjust the volume using thumbwheel **②**, the sound switches on automatically.

### Adjusting the volume

#### Adjusting the volume for the audio source

- ▶ Turn thumbwheel **②**.

or

- ▶ Press the **+** or **-** button on the multifunction steering wheel. The volume of the audio source currently selected changes.

#### Adjusting the volume for phone calls

You can adjust the volume for hands-free mode during a phone call.

- ▶ Turn thumbwheel **②** during a phone call.
- or
- ▶ Press the **+** or **-** button on the multifunction steering wheel during a telephone call.

### Adjusting the sound settings

#### Selecting the sound menu

The sound settings can be selected to suit a variety of different audio sources. You can access the sound menu for the current audio source (radio, CD, USB audio, Bluetooth® audio, Media Interface, AUX) using the respective basic menu.

#### Adjusting treble and bass

- ▶ Select **Sound** using the controller (slide **⬆**, **⬇**, **⬅** or turn **⌚**) and press **⏮** to confirm.
- ▶ Select **Treble** or **Bass** and press **⏮** to confirm.

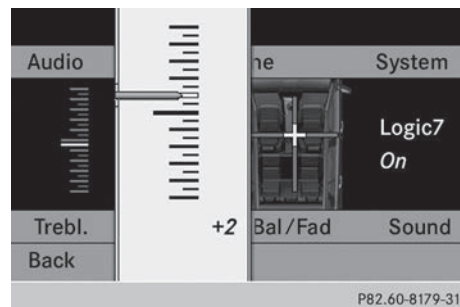

Example: setting the bass

The current setting is indicated by a red needle.

- ▶ **To change the setting:** slide **⬆** **⬇** or turn **⌚** the controller until the desired treble and bass levels are set. When you exit the menu, the current setting is stored.

### Adjusting balance and fader

With the balance function, you can control whether the sound is louder on the driver's or front-passenger side.

The fader function is used to control whether the sound is louder in the front or the rear of the vehicle.

Fader	Vehicle
Function available	C-Class, M-Class
Function not available	SLK

- ▶ Select **Sound** using the controller (slide  $\uparrow$ ,  $\leftarrow$  or  $\rightarrow$  or turn  $\odot$ ) and press  $\odot$  to confirm.
- ▶ Select **Balance** or **Bal/Fad** (balance/fader) and press  $\odot$  to confirm.

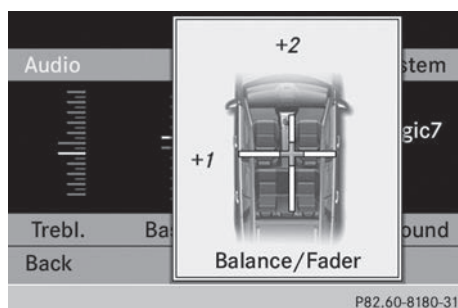

Example: adjusting the balance

- ▶ Select a balance setting by sliding  $\leftarrow$  or  $\rightarrow$  the controller and press  $\odot$  to confirm.
- ▶ Select a fader setting by sliding  $\uparrow$  or  $\downarrow$  the controller and press  $\odot$  to confirm. When you exit the menu, the current setting is stored.

### Surround sound

#### General notes

If your vehicle is equipped with the Harman Kardon® Logic 7® surround sound

system, you can choose between the settings **LOGIC7®On** and **LOGIC7®Off**.

The Harman Kardon® Logic 7® surround sound system is available for the following operating modes:

- audio CD
- MP3
- radio (FM) and satellite radio
- AUX

**i** If you select **LOGIC7®Off**, all permissible formats are played as stored on the medium. Due to the design of the passenger compartment, an optimum audio experience cannot be guaranteed for all passengers.

### Switching surround sound on/off

- ▶ Select **Sound** using the controller (slide  $\uparrow$ ,  $\leftarrow$  or  $\rightarrow$  or turn  $\odot$ ) and press  $\odot$  to confirm.

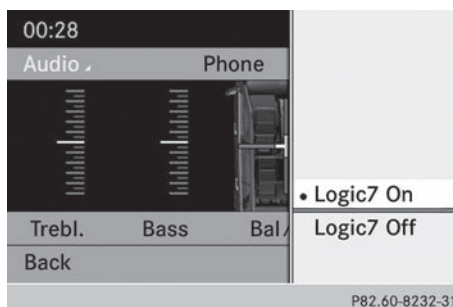

Example: setting surround sound

The **•** dot indicates the current setting.

- ▶ **To select a setting:** slide  $\uparrow$  or  $\downarrow$  or turn  $\odot$  the controller.
- ▶ **To save a setting:** press  $\odot$  the controller. The setting is stored and you exit the menu.

**i** The balance setting is automatically reset to the default value (0) when Logic 7® is switched on or off.

**i** Please bear the following in mind:

- To provide the optimum audio experience for all passengers when Logic 7<sup>®</sup> is switched on, the balance should be set to the center of the passenger compartment.
- MP3 tracks should have a bit rate of at least 128 kbit/s.
- Surround-sound playback does not function for mono signal sources, such as the medium wave range (MW) in radio mode.
- If radio reception is poor, e.g. in a tunnel, you should switch off Logic 7<sup>®</sup>. Otherwise, it may switch between stereo and mono and cause temporary sound distortions.
- On some stereo recordings, the sound characteristics may differ from conventional stereo playback.

## Rear Seat Entertainment

### Components

At a glance

#### Overview

The Rear Seat Entertainment System is comprised of:

- two rear-compartment screens behind the front-seat head restraints
- a remote control
- a CD/DVD drive
- AUX jacks on both screens (display AUX) and on the CD/DVD drive (drive AUX)
- two sets of cordless headphones

#### Rear-compartment screens



- ① AUX jacks, detailed view in the "CD/DVD drive and AUX jacks" section (▷ page 26)
- ② Display

## Remote control

### Overview



P82.87-6643-31

- ① To switch the screen on/off
- ② To switch the button lighting on/off
- ③ To select the screen for the remote control
- ④ To select a menu or menu item
- ⑤ To confirm a selection or setting
- ⑥ To switch the sound on/off (for corded headphones)
- ⑦ To adjust the volume (for corded headphones)
- ⑧ To skip to a track, fast-forward/fast-rewind
- ⑨ To select a track; direct entry
- ⑩ To exit a menu (back)

### Selecting the screen for the remote control

You can use the remote control to operate one of the two rear screens at a time. To do so, you must switch the remote control to the desired screen.

- ▶ **To select the left-hand screen:** turn thumbwheel ③ until "L REAR" is highlighted in the window.
- ▶ **To select the right-hand screen:** turn thumbwheel ③ until "REAR R" is highlighted in the window.

### Switching the screen on/off

- ❗ If the SmartKey is in position 0 or 1 in the ignition lock (see the vehicle Operator's Manual), or the SmartKey is not inserted, the screens in the rear will switch off after 30 minutes.

Before the screens switch off, they show a message to this effect.

You can switch the screens back on. However, this will discharge the starter battery.

- ▶ Point the remote control at the rear-compartment screen which has been selected for remote operation.
- ▶ Press button ① on the remote control. The respective rear screen switches on or off.
- ❗ You can only switch the screens on using the remote control if the ignition is switched on.

### Switching the button lighting on/off

- ▶ Press button ② on the remote control. Depending on the previous status, the button lighting is switched on or off.





- ❗ If you do not use the remote control for about 15 seconds, the button lighting switches off automatically.



### Mute

- ▶ Press button ⑥ on the remote control.  
The sound is on or off.

### Selecting a menu/menu item and confirming your selection

- ▶ Select a menu/menu item using the     buttons on the remote control and press the  button to confirm.

### CD/DVD drive and AUX jacks

The CD/DVD drive is located in the center behind the front seats.

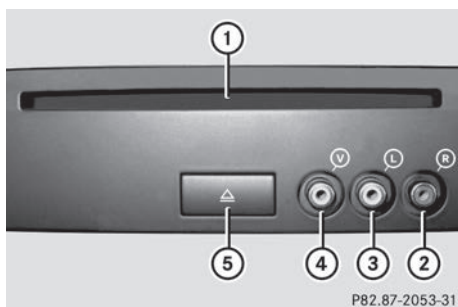

- ① CD/DVD slot
- ② AUX, right-hand (R) jack for audio signal
- ③ AUX, left-hand (L) jack for audio signal
- ④ AUX, jack for video signal (V)
- ⑤ CD/DVD eject button

The AUX jacks shown are for the AUX drive. Identical jacks can be found on the right-hand side of the rear-compartment screens (AUX display) (▷ page 24).

## Cordless headphones

### Overview



At a glance

- ① Volume control
- ② To select a screen for the headphones
- ③ Battery compartment cover
- ④ To switch the cordless headphones on/off
- ⑤ Indicator lamp with various displays (▷ page 27)

- ▶ Open both sides of the headphones and adjust the fit of the headphones by pulling the headphone band in the direction of the arrow.

### Switching the cordless headphones on/off

- ▶ Press button ④.  
Depending on the previous status, the headphones are switched on or off.  
To save the battery, the headphones are switched off automatically if they do not receive an audio signal within three minutes.

### Adjusting the volume of the headphones

- ▶ Turn volume control ① until the desired volume has been set.

- i** If you have connected corded headphones to a rear-compartment screen, you can adjust the volume by

pressing buttons ⑦ on the remote control (▷ page 25).

### Selecting a screen for the headphones

- ▶ Move push slider ② to **L** (left-hand screen) or **R** (right-hand screen).

### Indicator lamp displays

The color of the indicator lamp shows whether the headphones are switched on or off and indicates the charge level of the batteries inserted.

## At a glance

LED display	Status
Green	The batteries are fine.
Red	The batteries are almost discharged.
Lit continuously	The headphones are switched on and connected to a screen.
Flashing	The headphones are searching for the connection to a screen.
No display (dark)	The headphones are switched off or the batteries are discharged.

### Connecting additional headphones

You can connect one additional set of corded headphones to each of the two rear screens (▷ page 24). The socket is designed for headphones with a 3.5 mm stereo jack plug and an impedance of 32 ohms.

### Changing batteries

Batteries are required for the remote control and for the two sets of cordless headphones. For changing batteries, see (▷ page 90).

Audio system features .....	30
System menu .....	30
Switching the display on/off .....	30
Display settings .....	31
Time settings .....	31
Favorites button (asterisk key) .....	32
Bluetooth® settings .....	32
System language settings .....	33
Reset function .....	33

### Audio system features

- i** These Operating Instructions describe all standard and optional equipment available for your audio device at the time of going to print. Country-specific deviations are possible. Please note that your audio equipment may not offer all the features described.

### System menu

#### Calling up the System basic menu

- ▶ Press **sys**.
- or
- ▶ Select **System** from the main function bar using the controller (slide  $\odot \downarrow$ ,  $\leftarrow \odot \rightarrow$  or turn  $\text{⌂}(\odot \uparrow)$ ) and press  $\text{⏻}$  to confirm.

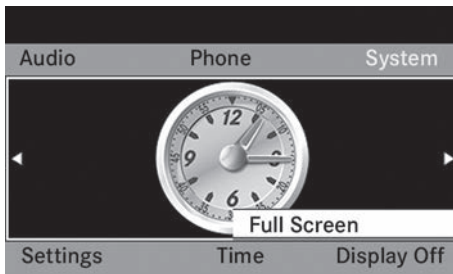

P82.60-8182-31

#### Full screen display

- ▶ With the **Full Screen** menu item highlighted, press  $\text{⏻}$  the controller. The main function bar and the submenu bar disappear.
- ▶ **To make the main function bar and submenu bar reappear:** press  $\text{⏻}$  the controller.



P82.60-8183-31

#### Changing the screen

You can change the screen to display either the clock or the consumption indicator.

- ▶ Slide  $\leftarrow \odot \rightarrow$  or turn  $\text{⌂}(\odot \uparrow)$  the controller. The display changes.

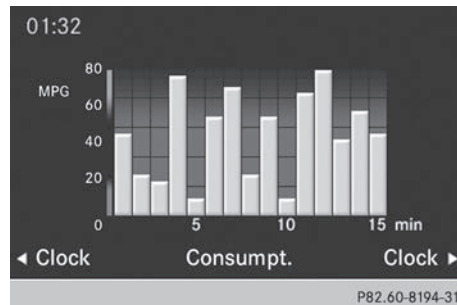

P82.60-8194-31

#### Switching the display on/off

- ▶ **To call up the basic menu:** press **sys**.
- ▶ Switch to the submenu bar by sliding  $\odot \downarrow$  the controller.
- ▶ Select **Display Off** by sliding  $\odot \rightarrow$  the controller and press  $\text{⏻}$  to confirm.
- ▶ **To switch the display on again:** press  $\text{⏻}$ .

or

- ▶ Press **ON**.

- i** You can also press one of the function buttons, such as the **DISC** button, to display the relevant basic menu.

## Display settings

### Display design

You can adjust the brightness of the display to suit the prevailing ambient light.

- ▶ **To call up the basic menu:** press **[SYS]**.
- ▶ Switch to the submenu bar by sliding **[↕]** the controller.
- ▶ Select **Settings** using the controller (slide **[↔]** or turn **[↻]**) and press **[✓]** to confirm.
- ▶ Select **Display** and press **[✓]** to confirm.
- ▶ Select **Brightness, Day Mode, Night Mode** or **Automatic** and press **[✓]** to confirm.

**i** If you select **Brightness**, an adjustment scale appears which you can use to adjust the brightness manually.

When the **Automatic** setting is selected, Audio 20 evaluates the readings from the automatic vehicle light sensor and switches between the display designs automatically.

## Time settings

### Accessing the date/time settings menu

- ▶ **To call up the basic menu:** press **[SYS]**.
- ▶ Switch to the submenu bar by sliding **[↕]** the controller.
- ▶ Select **Time** by sliding **[↔]** or turning **[↻]** the controller and press **[✓]** to confirm.

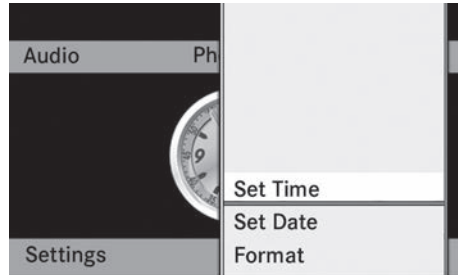

P82.60-8233-31

### Setting the time

- ▶ Select **Set Time** by sliding **[↕]** or turning **[↻]** the controller and press **[✓]** to confirm.

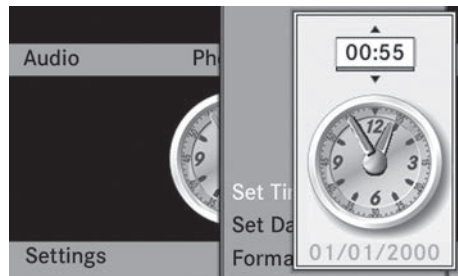

P82.60-8234-31

- ▶ **To set the time:** slide **[↕]** or turn **[↻]** the controller and press **[✓]** to confirm.

### Setting the date

- ▶ Select **Set Date** by sliding **[↕]** or turning **[↻]** the controller and press **[✓]** to confirm.

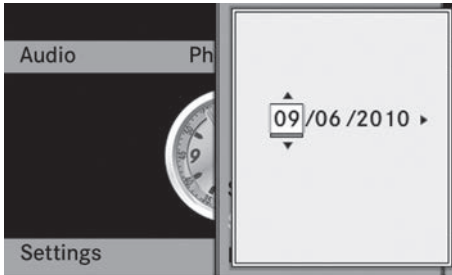

P82.60-8235-31

- ▶ **To set the date:** slide  $\uparrow\odot\uparrow$  or turn  $\left\{\begin{smallmatrix} \odot \\ \odot \end{smallmatrix}\right\}$  the controller and press  $\odot$  to confirm.

### Setting the format

- ▶ Select **Format** by sliding  $\uparrow\odot$  or turning  $\left\{\begin{smallmatrix} \odot \\ \odot \end{smallmatrix}\right\}$  the controller and press  $\odot$  to confirm.

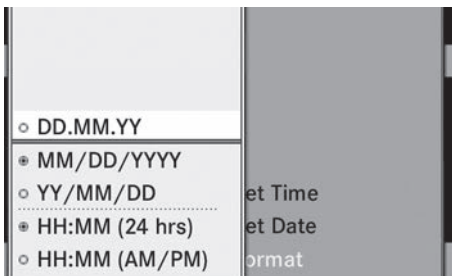

P82.60-8236-31

- i** You can set the format for the date and time separately.

- ▶ **To set the date/time format:** slide  $\uparrow\odot\uparrow$  or turn  $\left\{\begin{smallmatrix} \odot \\ \odot \end{smallmatrix}\right\}$  the controller and press  $\odot$  to confirm.

### Favorites button (asterisk key)

- i** You can assign a function from the favorites menu to the favorites button (star button) on the controller.

- ▶ **To call up the basic menu:** press  $\boxed{\text{SYS}\odot}$ .
- ▶ Switch to the submenu bar by sliding  $\odot\downarrow$  the controller.

- ▶ Select **Settings** using the controller (slide  $\leftarrow\odot$  or turn  $\left\{\begin{smallmatrix} \odot \\ \odot \end{smallmatrix}\right\}$ ) and press  $\odot$  to confirm.
- ▶ Select **Assign as Favorite** by sliding  $\uparrow\odot\downarrow$  the controller and press  $\odot$  to confirm.

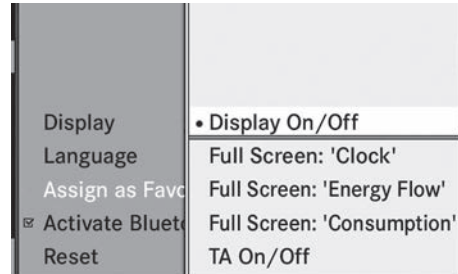

P82.60-8188-31

Favorites menu (example: vehicle with a favorites button)

- ▶ Select the desired function by sliding  $\uparrow\odot\downarrow$  the controller and press  $\odot$  to confirm.  
The selected function is assigned to the favorites button.

- i** If your vehicle has two favorites buttons, you can assign a function to each favorites button. The favorites menu will then have an additional submenu where you can choose the favorites button to which you want to assign a function.

## Bluetooth® settings

### General information about Bluetooth®

Bluetooth® technology is a standard for short-range wireless data transmissions up to approximately 10 meters. The Bluetooth® function must be activated in the Audio 20 system in order to call using hands-free mode and to receive electronic business cards (vCards).

Further information on telephone mode (> page 43).

Bluetooth® is a registered trademark of Bluetooth Special Interest Group (SIG) Inc.



### Activating/deactivating Bluetooth®

- ▶ **To call up the basic menu:** press **sys**.
- ▶ Switch to the submenu bar by sliding **☉** ↓ the controller.
- ▶ Select **Settings** using the controller (slide **←☉→** or turn **⌚**) and press **☑** to confirm.
- ▶ Select **Activate Bluetooth** using the controller (slide **↓☉↑**) and press **☑** to confirm.  
This switches Bluetooth® on  or off . Audio 20 is now ready to utilize Bluetooth® functions, such as receiving data from other devices or connecting mobile phones.

### System language settings

- ▶ **To call up the basic menu:** press **sys**.
- ▶ Switch to the submenu bar by sliding **☉** ↓ the controller.
- ▶ Select **Settings** using the controller (slide **←☉→** or turn **⌚**) and press **☑** to confirm.
- ▶ Select **Language** using the controller (slide **↑☉↓** or turn **⌚**) and press **☑** to confirm.
- ▶ Select the desired language and press **☑** to confirm.  
The menu system is shown in the selected language.

### Reset function

- i** You can reset Audio 20 to the factory settings. Among other things, this will delete all personal data (e.g. phone book entries), and all system settings are returned to the factory settings. A system reset is recommended, e.g. before selling the vehicle.
- ▶ **To call up the basic menu:** press **sys**.
- ▶ Switch to the submenu bar by sliding **☉** ↓ the controller.
- ▶ Select **Settings** using the controller (slide **←☉→** or turn **⌚**) and press **☑** to confirm.
- ▶ Select **Reset** and press **☑** to confirm.  
A prompt appears asking whether you wish to reset.
- ▶ Select **Yes** or **No**.  
If you select **Yes**, a prompt will appear again asking whether you really wish to reset.
- ▶ Select **Yes** or **No** and press **☑** to confirm.  
If you select **Yes**, Audio 20 will be reset and restarted.





Audio system features ..... 36  
Seat functions ..... 36  
Rear view camera ..... 38



### Audio system features

**i** These Operating Instructions describe all standard and optional equipment available for your audio device at the time of going to print. Country-specific deviations are possible. Please note that your audio equipment may not offer all the features described.

### Seat functions



#### Overview

The possible settings depend on the type of seat and the vehicle model series. For M-Class and GL-Class vehicles with multicontour seats, you can call up the following adjustment functions:



- seat cushion length
- backrest side bolsters
- lumbar
- massage

#### Selecting the seat

First select the seat which you wish to adjust.

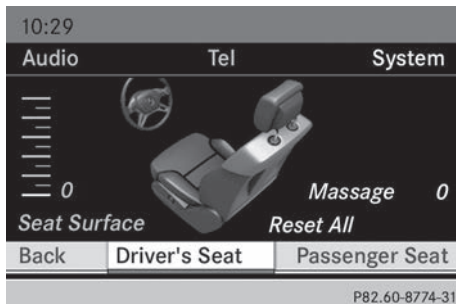
- ▶ Option 1: press the  button next to the controller.
- ▶ Option 2: press the  button.
- ▶ Select **Seat** and press  to confirm.



- ▶ To switch to the lower line, for both options slide  the controller.
- ▶ Select **Driver's Seat** or **Passenger Seat** by turning  the controller and press  to confirm.





### Adjustment functions

#### Adjusting the seat cushion

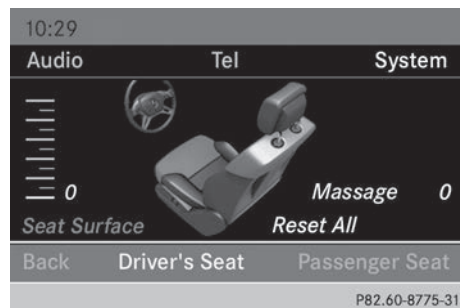
This function allows you to adjust the length of the seat cushion.



- ▶ Select the seat (▷ page 36).
- ▶ Select **Seat Surface** by turning  the controller and press  to confirm. A scale appears.



- ▶ Turn  or slide   the controller and press  to confirm.
- ▶ **To exit the menu:** press the  back button.

#### Adjusting the seat contour in the lumbar region of the seat backrest

This function allows you to adjust the air cushions in the lumbar region of the backrest (4-way lumbar support).

- ▶ Select the seat (▷ page 36).
- ▶ Select **Lumbar** by turning  the controller and press  to confirm. A crosshair appears. You can make two settings:

- **Vertical:** to move the point of greatest lumbar support up or down
- **Horizontal:** to adjust the amount of support



- ▶ Slide  $\uparrow \odot \downarrow$  or  $\leftarrow \odot \rightarrow$  the controller and press  $\odot$  to confirm.
- ▶ **To exit the menu:** press the  back button.

### Adjusting the sides of the seat backrest (backrest side bolsters)

- ▶ Select the seat ( $\triangleright$  page 36).
- ▶ Select **Seatb. Sides** by turning  $\left[ \odot \right]$  the controller and press  $\odot$  to confirm. A scale appears.

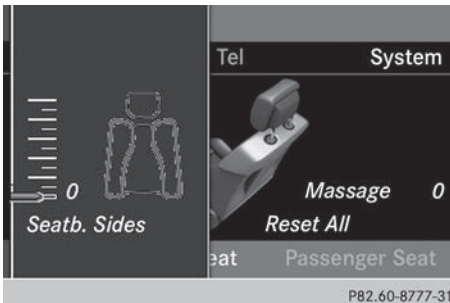

- ▶ Turn  $\left[ \odot \right]$  or  $\uparrow \odot \downarrow$  slide the controller and press  $\odot$  to confirm.
- ▶ **To exit the menu:** press the  back button.

### Massage function

- ▶ Select the seat ( $\triangleright$  page 36).
- ▶ Select **Massage** by turning  $\left[ \odot \right]$  the controller and press  $\odot$  to confirm. A list appears.

You can select different types of massage function:

- 0: Off
- 1: Slow and Gentle
- 2: Slow and Vigorous
- 3: Fast and Gentle
- 4: Fast and Vigorous

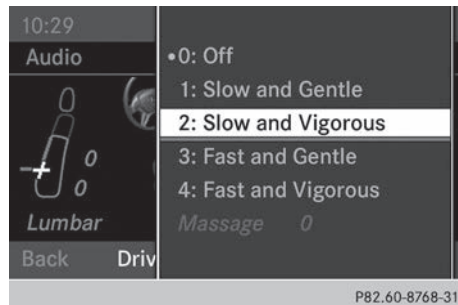

- ▶ Turn  $\left[ \odot \right]$  or slide  $\uparrow \odot \downarrow$  the controller and press  $\odot$  to confirm. The massage function runs for approximately 15 to 25 minutes, depending on the setting.
- ▶ **To exit the menu:** press the  back button.

### Resetting all adjustments

- ▶ Select the seat ( $\triangleright$  page 36).
- ▶ Select **Reset All** by turning  $\left[ \odot \right]$  the controller and press  $\odot$  to confirm. A prompt appears.



- ▶ Select **Yes** or **No** and press to confirm. If you select **No**, the process will be canceled. After you select **Yes**, all seat adjustments are reset to the default values (factory setting).

## Rear view camera

### Important safety notes

The rear view camera is only an aid. It is not a replacement for your attention to your immediate surroundings. You are always responsible for safe maneuvering and parking. When maneuvering or parking, make sure that there are no persons, animals or objects in the area in which you are maneuvering.

Under the following circumstances, the rear view camera will not function, or will function in a limited manner:

- the tailgate is open
- in heavy rain, snow or fog
- at night or in very dark places
- if the camera is exposed to very bright light
- if the area is lit by fluorescent light or LED lighting (the display may flicker)
- if there is a sudden change in temperature, e.g. when driving into a heated garage in winter
- if the camera lens is dirty or obstructed
- if the rear of your vehicle is damaged. In this event, have the camera position and

setting checked at a qualified specialist workshop.

### Activating/deactivating the display

If your vehicle is equipped with a rear view camera, you can choose to have the rear view camera switch on automatically. When you engage reverse gear, the image from the rear view camera will then be shown automatically on the Audio display. After completion of the maneuver, the audio display returns to the previous screen.

- i** Further information on the rear view camera driving system can be found in the vehicle Operator's Manual.
- ▶ Press the **sys** function button. The system menu appears.
- ▶ Select **Settings** by turning the controller and press to confirm.
- ▶ Select **Activation by R gear** and press to confirm. The function is switched on  or off , depending on the previous status.

Audio system features ..... 40  
Becker® MAP PILOT navigation  
module ..... 40



### Audio system features

**i** These Operating Instructions describe all standard and optional equipment available for your audio device at the time of going to print. Country-specific deviations are possible. Please note that your audio equipment may not offer all the features described.

### Becker® MAP PILOT navigation module

#### Important safety notes

##### WARNING

Operating the navigation system while driving may cause you to be distracted from the traffic conditions, cause an accident and injure yourself and others. For safety reasons, you should therefore only enter a new destination, for example, when the vehicle is stationary.

#### General notes

You can use the Becker® MAP PILOT navigation module to turn the Audio 20 into a full-fledged navigation system.

You can find more information under <http://www.beckermappilot.com>.

**i** If your vehicle is equipped with the Becker® MAP PILOT navigation module, you can slide the controller diagonally to move the map.

#### Audio fadeout

The audio fadeout function is only active when the Becker® MAP PILOT navigation module is connected. Audio fadeout reduces the volume of other audio sources, such as the radio or CD, when you receive a navigation message.

#### Audio fadeout on/off

- ▶ **To call up the basic menu:** press **sys**.
- ▶ Switch to the submenu bar by sliding **⊙↓** the controller.
- ▶ Select **Settings** using the controller (slide **←⊙→** or turn **⊙↻**) and press **⊙** to confirm.
- ▶ Select **Audio Fadeout** by sliding **↑⊙↓** the controller and press **⊙** to confirm. Switch the audio fadeout function on  or off .

Audio system features .....	42
General notes .....	42
Telephony via the Bluetooth® inter- face .....	43
Reception and transmission volume .	48
Using the telephone .....	49
Using the phone book .....	52
Using call lists .....	56
Using the speed dial list .....	58
Text messages .....	59



### Audio system features

**i** These Operating Instructions describe all standard and optional equipment available for your audio device at the time of going to print. Country-specific deviations are possible. Please note that your audio equipment may not offer all the features described.

You can obtain more detailed information on suitable mobile phones and on connecting Bluetooth®-capable mobile phones to Audio 20 from your authorized Mercedes-Benz Center or on the Internet at <http://www.mbusa-mobile.com> (customers in the USA only).

### General notes

#### Important safety notes

##### WARNING

If you operate mobile communication equipment while driving, you will be distracted from traffic conditions. You could also lose control of the vehicle. There is a risk of an accident.

Only operate this equipment when the vehicle is stationary.

Bear in mind that at a speed of just 30 mph (approximately 50 km/h), your vehicle is covering a distance of 44 feet (approximately 14 m) every second.

If you choose to use the mobile phone while driving, please use the hands-free device and only use the mobile phone when weather, road and traffic conditions permit.

#### Introduction

Audio 20 allows you to use a Bluetooth®-capable mobile phone via the Bluetooth® interface. Using the Bluetooth® interface and a suitable mobile phone, you can use the Audio 20 hands-free facility and receive vCards.

With a suitable mobile phone, you can use the hands-free system via the Bluetooth® interface, import contacts from the mobile phone via PBAP (Phone Book Access Profile) and receive vCards.







#### Call disconnection while the vehicle is in motion

A call may be disconnected if:

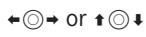
- there is insufficient network coverage in certain areas.
- you move from one transmitter/receiver area (cell) into another and no channels are free.
- you use a SIM card which is not compatible with the network available.
- you are using a mobile phone with "Twincard" and the mobile phone with the second SIM card is already logged into the network

#### Operating options

You can operate the telephone by using the following controls:

- Audio 20 controller  
Turn   
Slide  or   
Press 
- the  or  button and the number keypad on Audio 20
- using the  or  button on the multifunction steering wheel

All descriptions and illustrations in this section refer to the Audio 20 operating system unless stated otherwise.

### Function restrictions

The telephone is not ready for use in the following situations:

- the telephone automatically tries to log on to a network. If no network is available, you may not be able to make a "911" emergency call. If you attempt to make an outgoing call, the **No Service** message will appear for a short while.

If Audio 20 is switched off during a call in hands-free mode, the call is disconnected. This can be avoided by taking the following measure; before deactivating Audio 20, switch over to "Private Mode" on the mobile phone (see the mobile phone operating instructions).

### "911" emergency call

The 911 emergency call is a public service. Using it without due cause is a criminal offense.

The following requirements must be fulfilled for a 911 emergency call:

- the mobile phone must be switched on.
- a network must be available.
- a valid and operational SIM card must be inserted in the mobile phone.
- the mobile phone must be connected to Audio 20 via Bluetooth®.

If you cannot make an emergency call, you must arrange rescue measures yourself.

▶ Enter numbers on Audio 20 (▷ page 50).

▶ Press .

The telephone makes the connection.

▶ Wait until the emergency call center answers and describe the emergency situation.

### Telephony via the Bluetooth® interface

#### Prerequisites

To use Bluetooth® interface telephony in conjunction with Audio 20, you need a Bluetooth®-capable mobile phone.

#### On Audio 20

- ▶ Bluetooth® must be activated in Audio 20 (▷ page 33).

#### On the mobile phone

- ▶ Switch on the mobile phone and enter the PIN when prompted to do so (see the mobile phone operating instructions).
- ▶ Activate Bluetooth® functions and, where necessary, Bluetooth® visibility on the mobile phone (see the mobile phone operating instructions).

The battery of the mobile phone should always be kept sufficiently charged in order to prevent malfunctions.

In preparation for telephoning via the Bluetooth® interface, you should check the following items on your mobile phone (see the mobile phone operating instructions):

- Hands-Free Profile

The mobile phone must support Hands-Free Profile 1.0 or above.

- Bluetooth® visibility

On some mobile phones, it is not enough to activate only the Bluetooth® function. Your device must also be made "visible" to other devices (see the mobile phone operating instructions).

This visibility is for restricted periods of time on some mobile phones.

- Bluetooth® device name

Every Bluetooth® device has its own Bluetooth® device name. This device name is freely definable, but can be identical for all devices from the same manufacturer. It is therefore recommended that you change this name so that you can easily recognize

your mobile phone (see the mobile phone operating instructions).

- i** Not all mobile phones available on the market are equally suitable. You can obtain more detailed information about suitable mobile phones and about connecting Bluetooth®-capable mobile phones to Audio 20 on the Internet at <http://www.mbusa-mobile.com>. Or call the Mercedes-Benz Customer Assistance Center at 1-800-FOR-MERCEdes(1-800-367-6372) (for the USA) or Customer Relations at 1-800-387-0100 (for Canada).

- i** Some displays (e.g. the signal strength) depend on the supported version of the Hands-Free Profile.

### Connecting a mobile phone

#### General information

Before using your mobile phone with Audio 20 for the first time, you will need to authorize it. Device-specific information on connecting Bluetooth®-capable mobile phones can be found on the Internet at <http://www.mbusa-mobile.com>. Or call the Mercedes-Benz Customer Assistance Center at 1-800-FOR-MERCEdes(1-800-367-6372) (for the USA) or Customer Relations at 1-800-387-0100 (for Canada).

When you authorize a new mobile phone, it is connected automatically.

Connecting comprises:

- searching for a Bluetooth®-capable mobile phone
- subsequently authorizing it

You can authorize up to 15 mobile phones.



During connection, the phone book, call lists and text messages are automatically downloaded to Audio 20. This function must be supported by the connected mobile phone. You can suppress the automatic download of telephone data by deactivating

the "Import contacts" function (> page 55).

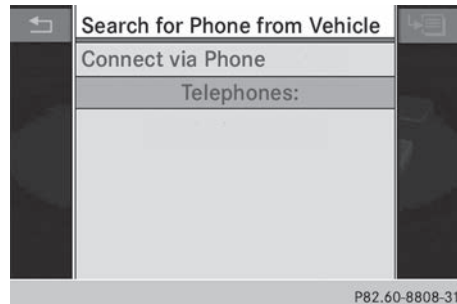

#### Searching for a mobile phone

- ▶ Press the **TEL** button on Audio 20.
- ▶ Select **Connect Device** in the telephone basic menu using the controller (slide  and turn ) and press  to confirm.



- ▶ Select **Search for Phone** and press  to confirm.  
A message appears.
- ▶ Select **Start Search** and press  to confirm.  
Audio 20 scans for Bluetooth® devices within range and enters them into the Bluetooth® phone list.  
If a new phone is found, it appears in the list with the  symbol.  
The duration of the search depends on the number of Bluetooth® telephones within range and their characteristics.

#### Symbols in the Bluetooth® phone list

Symbo l	Explanation
	New mobile phone in range, but not yet authorized
	Authorized mobile phone
•	Currently connected mobile phone

Symbol	Explanation
	Mobile phone in range and authorized
	Mobile phone not in range, but already authorized

The Bluetooth® telephone list shows all mobile phones within range and all previously authorized mobile phones, whether or not they are in range.

- i** If the Bluetooth® telephones list is already full, you will be requested to de-authorize a mobile phone (> page 47). If Audio 20 does not find your mobile phone, external authorization (> page 46) may be necessary.
- i** If you call up the telephone list again, the unauthorized devices are removed from the list. To update the Bluetooth® telephone list, start a new search.

### Authorizing a mobile phone

- ▶ Select the mobile phone that is not yet authorized from the Bluetooth® phone list by turning the controller.
- ▶ Select the list symbol to the right of the entry by sliding the controller and press to confirm.
- ▶ Select **Authorize** and press to confirm. The input menu for the passkey appears.

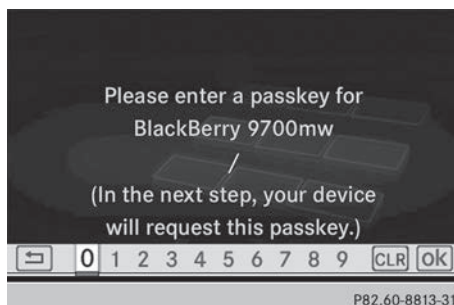

P82.60-8813-31

The passkey is any one to sixteen-digit number combination which you can choose yourself. You must enter the same number combination in Audio 20 and in the Bluetooth®-capable mobile phone (see the mobile phone operating instructions).

- i** Some mobile phones require a passkey with four or more digits.

If you reauthorize a mobile phone following deauthorization, you can select a different passkey.

- ▶ **To enter a passkey in Audio 20:** press the number keys in succession. is highlighted after the first number has been entered.
- or
- ▶ Select the numbers one after another by turning the controller and press to confirm. Then, select .
- ▶ **To confirm an entry in Audio 20:** press the controller.
- ▶ Now enter the same passkey in the mobile phone.

**To make entries on the mobile phone:** if the Bluetooth® connection is successful, you will be requested to enter the passkey (access code, code) (see the mobile phone operating instructions).

- ▶ Enter the same passkey in the mobile phone as already entered in Audio 20.

- i** After entering the passkey, you may also need to enter a confirmation in your mobile phone to connect calls. Please check your mobile phone display.

If the Audio 20 display shows the **Authorization failed** message, you may have exceeded the prescribed time period. Repeat the procedure.

The mobile phone is connected to Audio 20 (authorized). You can now use the Audio 20 hands-free function to make calls on your mobile phone.

**Option 2: via Secure Simple Pairing:** to connect via Secure Simple Pairing, the mobile phone (or Bluetooth® audio device) must support Bluetooth® Version 2.1. Audio 20 generates a six-digit numeric code that appears simultaneously on both devices that will be connected.

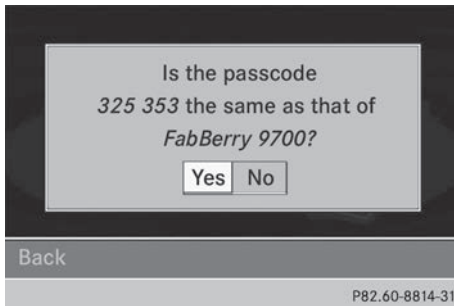

- ▶ If the numeric code on both devices matches, confirm **Yes** by pressing . If you select **Yes**, authorization is continued and the mobile phone is connected. If you select **No**, the process will be canceled.
- ▶ Confirm the message on the mobile phone.

### External authorization

If Audio20 is unable to detect your mobile phone, this may be due to your mobile phone security settings. In this case, please check to see whether your mobile phone can find the Audio 20 system. The Bluetooth® device name for Audio 20 is **MB Bluetooth**.

**Please note the following:** some mobile phones require that you establish the connection to Audio 20 again once you have entered the passkey (see the mobile phone operating instructions). The mobile phone cannot otherwise be authorized.

- ▶ Select **Connect Device** in the telephone basic menu by sliding and turning

the controller and press to confirm.

The Bluetooth® telephone list appears.

- ▶ Select **Search via Phone** and press to confirm. A message appears.

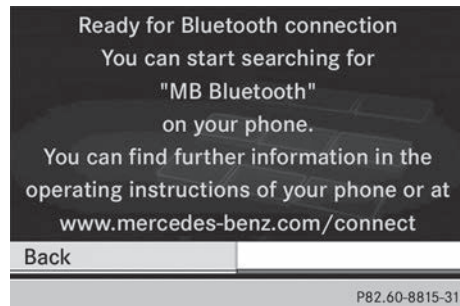

- ▶ Start the Bluetooth® search on the mobile phone (see the mobile phone operating instructions).
- ▶ Select **Audio 20 (MB Bluetooth)** on the mobile phone.
- ▶ **Option 1:** when requested to do so, enter the passkey on the mobile phone and then in the Audio 20 system.
- ▶ **Option 2:** confirm the numeric code on the mobile phone and in the Audio 20 system (Secure Simple Pairing). With both options, you see the prompt **Do you want <device name> to be authorized?** on the display.
- ▶ If you select **Yes**, the mobile phone will be authorized. The messages **Waiting for a Connection to <name of B-tooth dev.>...** and **Connecting Bluetooth Profiles...** are displayed. If the connection is successful, you see the telephone basic menu and the connected mobile phone is entered. If you select **No**, the process will be canceled.

### Reconnecting automatically

Audio 20 always searches for the last mobile phone connected.

If no connection can be made to the most recently connected mobile phone, the system searches for the mobile phone that was connected before that one.

### Switching between mobile phones

If you have authorized more than one mobile phone, you can switch between the individual phones.

- i** You can switch to another authorized mobile phone if you are not currently making a call.
- ▶ Select the mobile phone in the Bluetooth® telephones list by turning **⏮** the controller and press **⏹** to confirm. The selected mobile phone is searched for and connected if it is within Bluetooth® range and if Bluetooth® is activated. Only one mobile phone can be connected at any one time. The currently connected mobile phone is indicated by the • dot in the Bluetooth® telephones list.

### De-registering (deauthorizing) a mobile phone

Mercedes-Benz USA, LLC recommends de-authorization in Audio 20 as well as in the mobile phone. Subsequent authorization may otherwise fail.

- ▶ Press the **TEL** button on Audio 20.
- ▶ Select **Connect Device** in the telephone basic menu by sliding **⏮** and turning **⏮** the controller and press **⏹** to confirm. The Bluetooth® telephone list appears.
- ▶ Select the desired mobile phone in the Bluetooth® telephones list.

- ▶ Select the list symbol to the right of the entry by sliding **⏮** the controller and press **⏹** to confirm.
- ▶ Select **De-Authorize** and press **⏹** to confirm. A prompt appears asking whether you really wish to de-authorize this device.
- ▶ Select **Yes** or **No** and press **⏹** to confirm. If you select **Yes**, the device will be deleted from the phone list. If you select **No**, the process will be canceled.
- i** Before re-authorizing the mobile phone, you should also delete the device name **MB Bluetooth** from your mobile phone's Bluetooth® list.

### Displaying connection details

- ▶ Press the **TEL** button on Audio 20.
- ▶ Select **Connect Device** in the telephone basic menu by sliding **⏮** and turning **⏮** the controller and press **⏹** to confirm. The Bluetooth® telephone list appears.
- ▶ Select the mobile phone from the list.
- ▶ Select the list symbol to the right of the entry by sliding **⏮** the controller and press **⏹** to confirm.
- ▶ Select **Details** and press **⏹** to confirm. The following information concerning the selected mobile phone is shown:
 
  - Bluetooth® name
  - Bluetooth® address
  - availability status (shown after a search)
  - authorization status
- ▶ **To close the detailed display:** turn **⏮**, slide **⏮**, **⏮** or press **⏹** the controller.

### Telephone basic menu (Bluetooth® interface)

- ▶ Press the **TEL** button.

If the connected telephone is ready for use, the following display appears (example):

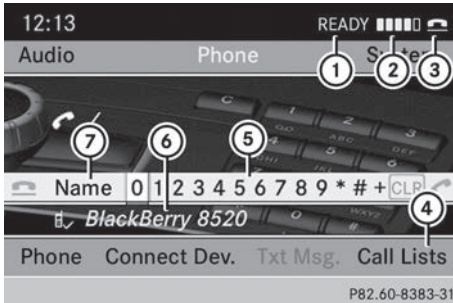

- 1 Network provider's name (depends on the connected phone)
- 2 Signal strength of mobile phone network
- 3 Receiver icon or
- 4 To display call lists
- 5 Character bar
- 6 Bluetooth® name of the currently connected mobile phone
- 7 To display the Audio 20 phone book

- ▶ Press **TEL**.

When the connected mobile phone is ready for use, the telephone basic menu appears.

- i** Bars **2** show the current signal strength of the mobile phone network. If all bars are filled, you have optimum reception.

If no bars are shown, reception is either very poor or there is none at all.

The receiver symbol shows whether a call is active/being connected or not .

### Text message display in the telephone basic menu

The **Text Message** menu item is only available if the Bluetooth® phone supports the Bluetooth® MAP profile (**M**essage **A**ccess **P**rofile). The downloading of text messages

from the Bluetooth® phone must have been completed. The menu item is otherwise grayed out.

If you have an unread text message, the mail symbol is displayed. The symbol disappears once you have read the text message. The mail symbol is displayed as soon as the text message memory is full. The symbol disappears once you delete at least one text message.

You can deactivate the automatic download function for text messages stored in the phone (▶ page 55).

You can choose not to display the stored text messages by activating the "Hide data" function (▶ page 56).

You will find further information in the "Text messaging (SMS)" section (▶ page 59).

### Reception and transmission volume

Once the mobile phone has been authorized, you can optimize the transmission and reception volume settings. Find information on the optimal setting for your mobile phone on the Internet at





<http://www.mbusa-mobile.com>. Or call the Mercedes-Benz Customer Assistance Center at 1-800-FOR-MERCEdes(1-800-367-6372) (for the USA) or Customer Relations at 1-800-387-0100 (for Canada).

- i** Incorrect settings may have an impact on the quality of calls.



- ▶ Press **TEL**.

- ▶ Select **Phone** from the telephone basic menu by turning the controller and press to confirm.

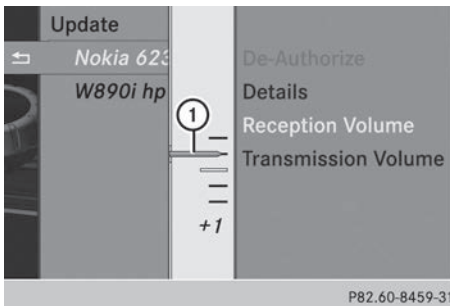

- ▶ Select **Connect Phones** and press  to confirm.
- ▶ Select an authorized mobile phone from the list by turning  the controller.
- ▶ Select the list symbol to the right of the entry by sliding  the controller and press  to confirm.
- ▶ Select **Reception Volume** or **Transmission Volume** and press  to confirm.



- ① Scale with indicator showing current volume
- ▶ Select a volume setting by turning  the controller.
- ▶ **To close the setting scale:** press  or slide .

## Using the telephone

### Incoming call

#### Rejecting or accepting a call

When you receive a call, you will hear a ring tone and the incoming call will appear in the display.

**i** Depending on the mobile phone, the Audio 20 ring tone may differ from the one you set. You could hear one of the following:

- the mobile phone ring tone
- the Audio 20 ring tone
- the Audio 20 ring tone and the mobile phone ring tone.

The name and number of the caller are displayed if:

- the caller's details are stored in the phone book
- the caller has enabled own number sending and
- the "Hide data" function is deactivated (default setting) (> page 56).

Otherwise, the following appears (example):

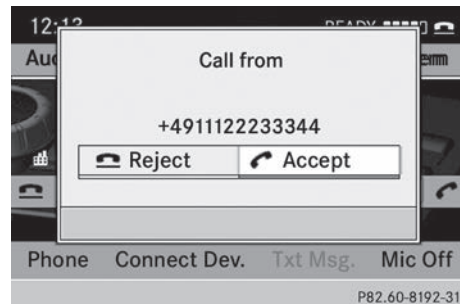



▶ **To accept:** press the  button on Audio20 or on the multifunction steering wheel.

or

▶ Press  the controller.

▶ **To reject:** press the  button on Audio20 or on the multifunction steering wheel.

or

▶ Select **Reject** using the controller (slide  or turn ) and press  to confirm.



Once you have accepted the call, you can use hands-free mode. You can adjust the call volume (> page 21). For more information,



see the "Functions available during a call" section (► page 52).

**i** You can also accept a call if the display is showing a display other than the telephone mode. Once you have accepted the call, the display shows telephone mode. After the call is finished, you see the display of the previous main application again.







The display does not switch to telephone mode if you:

- ▶ hide the window using the  button next to the controller
- ▶ accept the call using the  button on the multifunction steering wheel
- ▶ accept the call using the  button on Audio 20



### Making a call

#### Entering a telephone number using the number keypad

You can use the number keypad to enter numbers and special characters.

- ▶ **To enter:** use the  to , and  buttons to enter the characters. For the \* character, press the  button once. Press the button a second time within 1.5 seconds for the + character.
- ▶ **To delete individual digits:** press the  button.
- ▶ **To delete an entire number:** press and hold the  button until the entire number has been deleted.

or









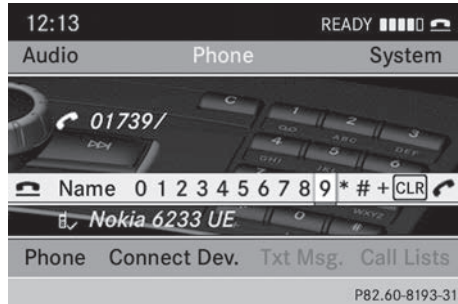







- ▶ Press the  button.
- ▶ **To finish entry and make a call:** press the  button.

#### Entering a telephone number using the character bar

In addition to the menu bar, a character bar is displayed in the telephone basic menu.

If the character bar is active (highlighted), you can select an item.



- ▶ **To enter digits:** slide  or turn  the controller until the desired number is selected.
  - ▶ **To confirm your selection:** press  the controller.
  - ▶ Repeat this procedure to select all of the desired digits in sequence from the character bar.
  - ▶ **To delete individual digits:** slide  or turn  the controller until  is selected.
  - ▶ Press  the controller.
  - ▶ **To delete a number sequence:** slide  or turn  the controller until  is selected.
  - ▶ Press  the controller until the number sequence is deleted.
- or
- ▶ Select  by sliding  or turning  the controller and press  to confirm.
  - ▶ **To make a call:** select  and press  to confirm.

### Using a number from the phone book

- ▶ Select **Name** by sliding ←○→ or turning Ⓜ the controller and press Ⓜ to confirm.
- ▶ Select the entry by sliding ↑○↓ or turning Ⓜ the controller and press Ⓜ to confirm (▷ page 54).
- ▶ Press the  button or the Ⓜ controller.

**i** Operation using the multifunction steering wheel (▷ page 55)

### Dialing a telephone number from a call list

- ▶ Select **Call Lists** by sliding ○↓, ←○→ or turning Ⓜ the controller and press Ⓜ to confirm.
- ▶ Select **Calls Received** or **Calls Dialed** and press Ⓜ to confirm.
- ▶ Select the entry and press Ⓜ to confirm (▷ page 57).
- ▶ Press the  button or the Ⓜ controller.

**i** Operation using the multifunction steering wheel (▷ page 57)

### Redialing

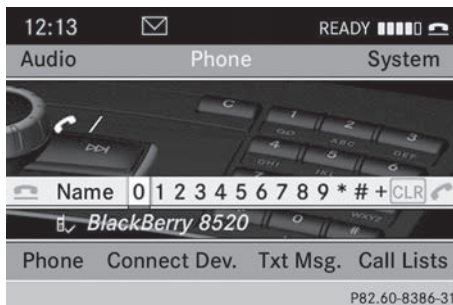

**i** Requirement: no characters should have been entered.



- ▶ Press the  button.
- or
- ▶ Select  and press Ⓜ the controller. The most recently dialed telephone numbers are displayed.

- ▶ Select the desired telephone number.
- ▶ Press the  button.

or

- ▶ In the telephone basic menu in the instrument cluster: press the  button on the multifunction steering wheel.

### Canceling dialing or ending a call

- ▶ Select  in the display by sliding ○↓, ←○→ or turning Ⓜ the controller and press Ⓜ to confirm.
- ▶ Press the  button on Audio20 or on the multifunction steering wheel.

### Making a call via speed dial

The speed dial list contains stored phone book entries (▷ page 58).

#### Option 1:

- ▶ Hold down one of the number keys for longer than two seconds.

#### Option 2:





- ▶ Call up the telephone basic menu:
  - Telephony via the Bluetooth® interface (▷ page 48)
- ▶ Select **Call Lists** by sliding ○↓, ←○→ or turning Ⓜ the controller and press Ⓜ to confirm.
- ▶ Select **Speed Dial Preset List** by turning Ⓜ the controller and press Ⓜ to confirm. The speed dial list appears.
- ▶ Select preset and press Ⓜ to confirm. Irrespective of the option chosen, the telephone basic menu appears and

displays the selected entry. This initiates dialing.

### Functions available during a call

#### Switching the hands-free microphone on/off

The menu bar changes when you make a call. Instead of the **Call Lists** menu item, you will see **Mic Off** or **Mic On**.

- ▶ **To switch off:** select **Mic Off** by sliding ,  or turning  the controller and press  to confirm.

The message: **The microphone is off** appears briefly.

If the microphone is switched off the  icon appears in the main area. The person on the line can hear nothing from your vehicle.

- ▶ **To switch on:** select **Mic On** and press  to confirm.

The message: **The microphone is on** appears briefly.

The  symbol disappears.



#### Sending DTMF tones





- i** This function is not supported by all mobile phones.

Answering machines or other devices can be controlled by DTMF tones, e.g. for remote query functions.

- ▶ During an active call, press the respective keys on the number keypad. Every character selected will be transmitted immediately.

or

- ▶ **To select a character:** slide ,  or turn  the controller.

- ▶ **To confirm your selection:** press  the controller.
- ▶ **To send a phone book entry as a DTMF sequence:** select **Name** by turning  the controller and press  to confirm.
- ▶ Select the desired phone book entry and press  to confirm. The entry is sent as a DTMF character string.
- ▶ **To return to the call display:** select **Back** and press  to confirm.

## Using the phone book

### Introduction

If the mobile phone supports downloading contacts via PBAP (Phone Book Access Profile), the mobile phone book will automatically download to the Audio 20 system when connected. You can also import contacts to the phone book from a USB device or use Bluetooth® to receive vCards.

- i** The phone book can store between 1,000 and 2,000 entries, depending on the size of the entries. Imported vCards are given priority when storing and overwrite existing PBAP contacts if the memory is full.

- i** Imported contacts are stored permanently in the phone book. For this reason, you should delete the call lists before selling the vehicle.

### Importing external data

#### Receiving vCards (via the Bluetooth® interface)

Received vCards are identified by the  symbol.

You can import vCards from external Bluetooth®-capable phones into the address book. Please bear the following in mind:

- Bluetooth® must be active on Audio 20 and on the external Bluetooth®-capable telephone; see (> page 33) and the operating instructions of the respective mobile phone.
- the external Bluetooth® phone must be able to send vCards via Bluetooth® (see the operating instructions of the respective mobile phone).

**i** If you switch to another operating mode during vCard reception (e.g. if you press the **RADIO** button), vCard reception is canceled.

- ▶ Select **Phone** using the controller (slide **⊙** ↓, ← **⊙** → or turn **⌂** (⊙) ⌂) and press **⊙** to confirm.

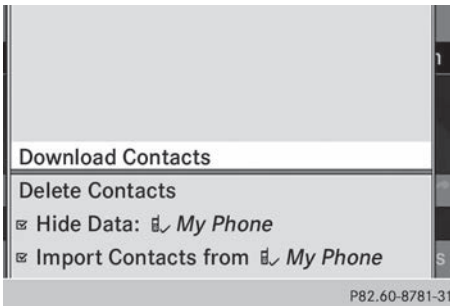

- ▶ Select **Download Contacts** and press **⊙** to confirm.  
A submenu is displayed.
- ▶ Select **Receive Contacts From Phone** and press **⊙** to confirm.  
The Bluetooth® connection between Audio 20 and your active mobile phone is interrupted. Audio 20 is now ready to receive vCards from other mobile phones.
- ▶ Start data transfer on the external Bluetooth® phone (see the operating instructions of the respective mobile phone).

The data on the vCards is automatically transferred to the address book. The number of vCards received is displayed.

- ▶ **To cancel reception:** select **Back** and press **⊙** to confirm or switch to a different operating mode.

### Importing from a USB device

Imported USB device entries are marked with the  symbol.

The following conditions must be fulfilled in order to import vCards:

- vCards (vcf files) can be placed in folders. Audio 20 allows you to select the relevant folders directly.
- vCards must have the file extension ".vcf".

**i** A vCard file can also contain several vCards.

Audio 20 supports vCards in versions 2.1 and 3.0.

- ▶ Select **Phone** from the telephone basic menu by sliding **⊙** ↓ and turning **⌂** (⊙) ⌂ the controller and press **⊙** to confirm.
- ▶ Select **Import Contacts** and press **⊙** to confirm.  
A menu appears.
- ▶ Select **From USB Device** from the menu by turning **⌂** (⊙) ⌂ the controller and press **⊙** to confirm.
- ▶ Select **Add** or **Overwrite** and press **⊙** to confirm.  
**Add** imports the entries from the USB device to the phone book.  
**Overwrite** imports the entries from the USB device and overwrites all entries in the phone book marked with the  symbols. The previous entries are then no longer available.  
After the contact data has been imported successfully, you will see a message to this

effect. The corresponding telephone basic menu appears.

- ▶ You can select the **Overwrite** menu item if the phone book already contains corresponding entries. A message notifies you if the phone book is full.

### Calling up the phone book

#### Overview

- ▶ Select **Name** using the controller (slide  $\odot$  ↓, ← $\odot$ → or turn  $\odot$  ↻) and press  $\odot$  to confirm.

If the phone book contains entries, these will be displayed in alphabetical order. The character bar will be shown in the lower section and is active.

The character bar serves to reduce the number of entries needed.



- ▶ **To switch from the character bar to the list:** slide  $\odot$  ↑ the controller or press  $\odot$  repeatedly until the character bar disappears.
- ▶ **To switch from the list to the character bar:** press the **BACK** button on the controller.

#### Symbol overview

Symbol	Explanation
	Contact imported from a mobile phone that supports PBAP
	Entry imported from the USB device
	Entry imported via the Bluetooth® interface

#### Selecting an entry using the character bar

##### Selecting a character from the character bar

- ▶ First switch to the character bar when the list appears.

You determine the first letter of the entry you are looking for with the first character you enter.

- ▶ Slide ← $\odot$ → or turn  $\odot$  ↻ the controller.
- ▶ **To confirm your selection:** press  $\odot$  the controller.

The first entry in the list that starts with the letter selected is highlighted. If there are similar entries, the next different character is shown. For example, with entries such as **H**ilden and **H**ilgers, the beginnings of the names are similar. In this case, you will be offered a choice between **D** and **G**.



- ▶ Select the characters of the entry you are searching for one by one and press  $\odot$  to confirm.

As soon as you make a clear selection, Audio 20 switches automatically to the list.



- ▶ **To complete the search:** switch from the character bar to the list.

The first list entry is automatically highlighted.

### Changing the language of the character bar



- ▶ Select  and press  to confirm.
- ▶ Select the desired language and press  to confirm.

### Changing the character set of the character bar





- ▶ Select  and press  to confirm.  
Depending on the previous setting, the entry mode changes to special characters or to letters with numbers.

### Selecting an entry directly from the list

#### Using the controller



- ▶ You can switch to the list after the character bar appears.
- ▶ Turn  or slide  the controller to select an entry and press  to confirm.





#### Using the buttons on the multifunction steering wheel

- ▶ In the telephone basic menu in the instrument cluster: press the  or  button briefly.  
The previous/next entry in the phone book is displayed.
- ▶ In the telephone basic menu in the instrument cluster: press and hold the  or  button for longer than two seconds.  
The first entry in the list that has the previous/next first letter in the phone book is shown.
- ▶ **To make a call:** press .

### Displaying details for an entry







Audio 20 can also display a shortened entry in full.

- ▶ Select an entry from the list.
- ▶ Select the list symbol to the right of the entry by sliding  the controller and press  to confirm.

- ▶ Select **Details** and press  to confirm.  
The detailed view appears.
- ▶ **To close the detailed display:** turn  or slide  or  the controller and press .



### Deleting contacts

This function allows you to delete personal data from the phone book.

- ▶ Select **Phone** using the controller (slide ,  or turn ) and press  to confirm.
- ▶ Select **Delete Contacts** and press  to confirm.  
A prompt appears asking whether the data should be deleted.
- ▶ Select **Yes** or **No** and press  to confirm.

### Switching importing of contacts on/off

You can choose whether contacts are to be automatically downloaded when a mobile phone is connected to Audio 20.

- ▶ Connecting a mobile phone (▷ page 44)
- ▶ Select **Phone** from the telephone basic menu by sliding  and turning  the controller and press  to confirm.  
A menu appears.





- ▶ Select **Import Contacts from <My Phone>** and press  to confirm. You can allow  or suppress  the automatic download.

### Switching the display of contact details (privacy) on/off

The **Hide Data** setting allows you to decide whether telephone and address book data is visible on the screen. You can therefore, for example, prevent a passenger from seeing the name of a caller.

Activating the function has the following effects:

- The mobile phone's phone book data is hidden. Therefore, you cannot use the data to make a call. You still have access to the phone book data stored in Audio 20.
- During incoming calls, the caller's name is not displayed even if there is a phone book entry for the number that is calling.
- During outgoing calls where the number is entered manually, the recipient's name is not displayed, even if there is a phone book entry for the entered number.
- The call list is hidden.
- Redialing is not possible.
- The received text messages list is hidden. There is still a notification for incoming text messages. For this to be the case, the connected mobile phone must support the MAP profile. However, it is not possible for the passenger, for example, to view the phone number or access the data.
- ▶ Connecting a mobile phone (▷ page 44).
- ▶ Select **Phone** from the telephone basic menu by sliding  and turning  the controller and press  to confirm. A menu appears.

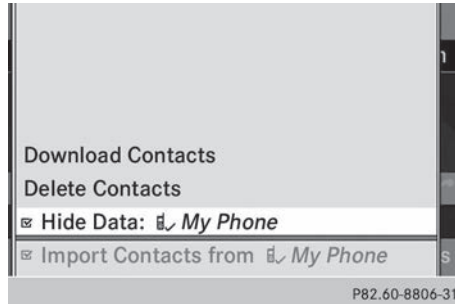

- ▶ **To hide data:** select **Hide Data: <My Phone>** and press  to confirm. You can allow access to phone book data  or you can prevent access .

## Using call lists

### Introduction

Audio 20 displays calls dialed and received (including missed calls) during phone operation in separate lists. Call lists are not available unless a mobile phone is connected with Audio 20.

Audio 20 supports the PBAP Bluetooth® profile. For this reason, note that the system behavior differs, especially when telephoning via the Bluetooth® interface:

- Bluetooth® telephone with PBAP Bluetooth® profile: the call lists are downloaded automatically by Audio 20 as soon as the mobile phone is connected to Audio 20.
- Bluetooth® telephone without PBAP Bluetooth® profile: the call lists are generated and displayed by Audio 20.

You can deactivate the automatic download function for contacts and call lists stored in the phone (▷ page 55).

If you have activated the "Hide data" function, Audio 20 does not display the call lists (▷ page 56).



- i** Bluetooth® phones without PBAP Bluetooth® profile: the call lists generated by Audio 20 are not synchronous with the call lists of your mobile phone. These calls may or may not be listed on your mobile phone, depending on the model.
- i** If no mobile phone is connected, then the **Call Lists** menu item is grayed out and cannot be selected. If you connect a different mobile phone with Audio 20 then the previously available call lists and their entries will be deleted automatically. They are still available on the mobile phone itself.
- i** The respective menu item can only be selected if calls have been received or made using Audio 20.

#### Opening the call list and selecting an entry

- ▶ Select **Call Lists** using the controller (slide  $\odot \updownarrow$ ,  $\leftarrow \odot \rightarrow$  or turn  $\{\odot\}$ ) and press  $\odot$  to confirm.
- ▶ Select **Calls Received** or **Calls Dialed** and press  $\odot$  to confirm. The corresponding list appears.

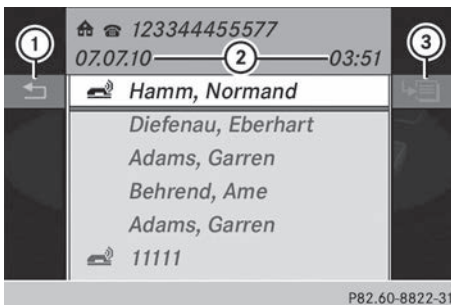

- ① To close the list
- ② Date/time (if available), symbols (if assigned) and telephone number of the entry highlighted
- ③ To call up options

Missed calls are marked by the telephone symbol to the left of the name or the number.

- i** You can also call up the list of dialed calls by pressing the button when the telephone basic menu is shown. In this case, the list will only show phone numbers.

▶ **To select a list entry:** slide  $\up \odot \down$  or turn  $\{\odot\}$  the controller.

▶ **To make a call:** press  $\odot$  the controller or the button.

#### Using the buttons on the multifunction steering wheel

- ▶ In the telephone basic menu in the instrument cluster: press the button. The **Calls Dialed** call list is shown. The entry at the top of the list (the last number dialed) is marked.

▶ **To select a list entry:** press the  $\blacktriangle$  or  $\blacktriangledown$  button.

▶ **To make a call:** press .

#### Displaying details from a list entry

Audio 20 can also show a shortened list entry in full.

- ▶ Select a list entry by turning  $\{\odot\}$  the controller.
- ▶ Select the list symbol to the right of the entry by sliding  $\odot \rightarrow$  the controller and press  $\odot$  to confirm.
- ▶ Select **Details** and press  $\odot$  to confirm. The detailed view appears.
- ▶ **To go back to the list:** slide  $\leftarrow \odot \rightarrow$  repeatedly until the list is highlighted.

#### Deleting call lists

This function is available if Audio 20 creates and manages call lists. This is the case if you use a Bluetooth® telephone without the support of the PBAP Bluetooth® profile.



- ▶ Select **Call Lists** from the telephone basic menu by turning the controller and press to confirm.
- ▶ Select **Delete Call Lists** and press to confirm.  
A prompt appears asking whether you wish to delete all call lists.
- ▶ Select **Yes** or **No** and press to confirm.  
If you select **Yes**, the call lists are deleted.  
If you select **No**, the process will be canceled.

The next available speed dial preset is highlighted.

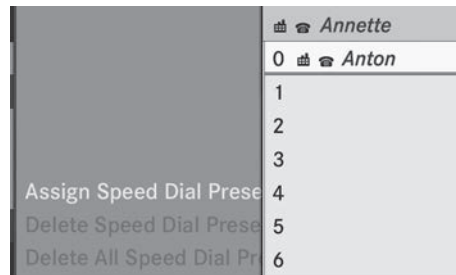

P82.60-8250-31

### Using the speed dial list

#### Storing a phone book entry in the speed dial list

You can assign ten speed dial presets (0 – 9) to the speed dial list.

##### Option 1:

- ▶ Search for a phone book entry in the phone book (▷ page 54).
- ▶ Select the list symbol to the right of the entry by sliding the controller and press to confirm.  
A menu appears.
- ▶ Select **Speed Dial** by turning the controller and press to confirm.  
A menu appears.

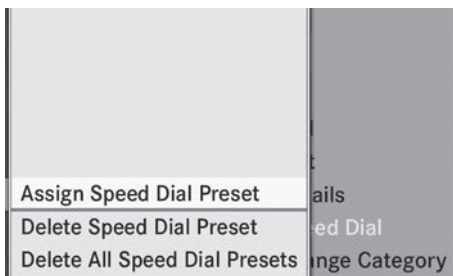

P82.60-8249-31

Speed dial menu

- ▶ Select **Assign Speed Dial Preset** using the controller and press to confirm.  
The speed dial list appears. The selected phone book entry is listed as the first entry.

- ▶ Select the speed dial preset by turning the controller and press to confirm.  
The phone book entry is saved in the speed dial preset.

##### Option 2:



- ▶ Call up the telephone basic menu:
  - Telephony via the Bluetooth® interface (▷ page 48)
- ▶ Select **Call Lists** using the controller (slide and turn ) and press to confirm.
- ▶ Select **Speed Dial Preset List** and press to confirm.  
The speed dial list appears.
- ▶ Select the list symbol to the right of the entry by sliding the controller and press to confirm.
- ▶ Select **Assign Speed Dial Preset** and press to confirm.
- ▶ Proceed as described under option 1.



#### Making a call via speed dial

A description can be found in the "Telephone operation" section (▷ page 51).

#### Deleting a speed dial number

- ▶ **To delete a speed dial preset:** select **Delete Speed Dial Preset** from the

speed dial menu by turning  the controller and press  to confirm. The speed dial number is deleted.

- ▶ **To delete all speed dial presets:** select **Delete All Speed Dial Presets** from the speed dial menu by turning  the controller and press  to confirm. You will be asked whether you want to continue.
- ▶ Select **Yes** or **No** and press  to confirm. If you select **Yes**, all speed dial presets will be deleted from the speed dial list. If you select **No**, the process will be canceled.

## Text messages

### Information and requirements



The following conditions must be met in order to use the functions:

The Bluetooth® mobile phone supports the MAP Bluetooth® profile (**M**essage **A**ccess **P**rofile).

When the mobile phone is connected, the 30 most recent text messages currently stored in the phone's text message inbox are loaded to Audio 20's text message (SMS) inbox and displayed.

 Audio 20 does not load all the newest text messages:





This may occur in exceptional cases, for example when using certain mobile phones and when the mobile phone inbox holds many text messages.

Once the above conditions are met, new text messages arriving in the Audio 20 text message inbox are displayed. In addition, a tone sounds and the  icon appears. The symbol disappears after the text message has been read. The  mail symbol is displayed if the text message memory is full. The symbol

disappears after at least one text message has been deleted.

## Displaying the text message inbox

### Overview

- ▶ Select **Text Message** using the controller (slide ,  or turn ) and press  to confirm. The list of received text messages appears. Unread messages are displayed using the  message icon.



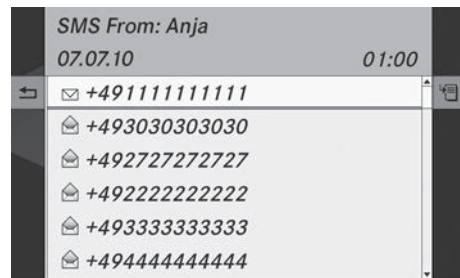



There are two types of display: the sender display and the text display.



P82.87-6405-31

The sender display shows the sender of the text message. If the sender is stored in the phone book, the name will be displayed. If the sender is not stored in the phone book, the telephone number will be displayed.

The text display shows the first few words of the text message.

- ▶ **To switch to text display:** select the list symbol to the right of the text message by sliding  the controller and press  to confirm.
- ▶ Select **Display Text** and press  to confirm. The view changes.
- ▶ **To switch to the sender display:** select **Display Sender** and press  to confirm. The view changes.
- ▶ **To select a text message:** turn  or slide  the controller.

### Reading a text message

- ▶ Select **Text Message** using the controller (slide  $\odot \downarrow$ ,  $\leftarrow \odot \rightarrow$  or turn  $\updownarrow \odot \updownarrow$ ) and press  $\odot$  to confirm.
- ▶ Select a text message and press  $\odot$ .  
The text message appears.
- ▶ **To scroll through the display or select telephone numbers in the text:** turn  $\updownarrow \odot \updownarrow$  or slide  $\up \odot \downarrow$  the controller.  
The display scrolls up or down line by line, or skips to the next or previous telephone number and automatically highlights it.
- ▶ **To return to the list:** press  $\odot$ , or select **Back** and press  $\odot$  to confirm.

### Displaying details

Audio 20 can also show the full details instead of the shortened sender view.

- ▶ Select a text message and press  $\odot$  to confirm (▷ page 59).
- ▶ Select the list symbol to the right of the text message by sliding  $\odot \rightarrow$  the controller and press  $\odot$  to confirm.
- ▶ Select **Details** and press  $\odot$  to confirm.  
The detailed view appears.
- ▶ **To close the detailed view:** slide  $\leftarrow \odot \rightarrow$  or press  $\odot$  the controller.

### Managing text messages

#### Calling a text message sender

- ▶ Press  $\odot$ , select **Call Sender** and press  $\odot$  to confirm.

#### Using phone numbers in the text

- i** This function requires that the text message contain numbers that can be interpreted as telephone numbers.
- ▶ **To call the telephone number used in the text message:** highlight the telephone

number, press  $\odot$  the controller, select **Call Number** and press  $\odot$  to confirm.

### Deleting a text message

The  symbol is displayed when the text message memory is full. In order to be able to receive new text messages, you must delete old messages.

- i** This function deletes a text message from Audio 20 and the mobile telephone. Some mobile phones do not support this function. In such cases, the text message is only deleted from the memory of Audio 20.

Select **Text Message** using the controller (slide  $\odot \downarrow$ ,  $\leftarrow \odot \rightarrow$  or turn  $\updownarrow \odot \updownarrow$ ) and press  $\odot$  to confirm.

- ▶ Select a text message and press  $\odot$  to confirm (▷ page 59).
- ▶ Select the list symbol to the right of the text message by sliding  $\odot \rightarrow$  the controller and press  $\odot$  to confirm.
- ▶ Select **Delete** and press  $\odot$  to confirm.  
A prompt appears asking whether the data should be deleted.
- ▶ Select **Yes** or **No** and press  $\odot$  to confirm.  
The text message will either be deleted or not, depending on your selection.

Audio system features .....	62
Radio mode .....	62
Satellite radio .....	66
Audio CD and MP3 mode .....	70
Bluetooth® audio .....	77
Operation with the Media Interface ..	82
Audio AUX mode .....	87

### Audio system features

- i** These Operating Instructions describe all standard and optional equipment available for your audio device at the time of going to print. Country-specific deviations are possible. Please note that your audio equipment may not offer all the features described.

### Radio mode

#### Important notes

Portable electronic devices in the vehicle may seriously impair radio reception.

#### Switching to radio mode

#### Switching modes using the function button

- ▶ Press the **RADIO** function button. The radio display appears.
  - Radio mode:** you will hear the last station played on the last waveband selected.
- i** Repeatedly pressing the **RADIO** function button switches between the FM, AM and WB wavebands in that order and then calls up satellite radio mode. Pressing the button again takes you back to FM radio mode.

#### Switching modes via the audio menu

- ▶ Select **Audio** from the main function bar using the controller (slide **↑** and turn **⏪**) and press **⏩** to confirm. If radio mode was the last mode selected, it will now be active. If another audio mode is switched on, you can now switch to radio mode in the audio menu.

### Radio display

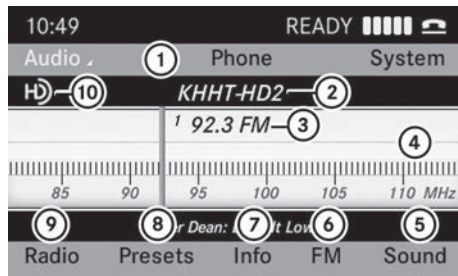

P82.60-8201-31

#### Radio display

- ① Main function bar
  - ② Display showing station name (if available)
  - ③ Frequency of the selected station
  - ④ Display/selection window showing station name or frequency
  - ⑤ Sound settings
  - ⑥ To switch between FM, AM, WB and satellite radio
  - ⑦ To display radio text
  - ⑧ Memory functions
  - ⑨ Radio functions
  - ⑩ HD Radio logo (only with HD Radio reception)
- i** If the station supports radio text and information is available, the system shows it below the display/selection window.

#### Switching HD Radio on/off

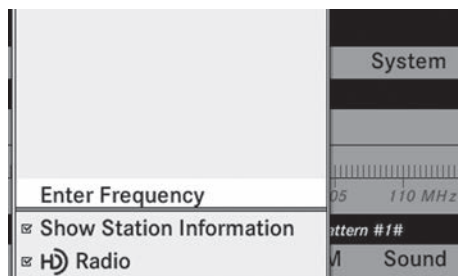

P82.60-8176-31

You can switch off HD Radio™ in the radio submenu:

- ▶ Select **Radio** in the radio display by sliding the controller and press to confirm.
- ▶ Select **HD Radio** and press to confirm.  
 HD Radio™ on:   
 HD Radio™ off:

### Notes on HD Radio™:

HD Radio™ is a digital radio system from the U.S.A. When HD Radio is off, you will hear only analog programming on all frequencies.

HD Radio™ provides:

- digital transmission on the same wavebands as analog AM/FM. The analog AM/FM stations remain in the same position when selecting a station.
- broadcasting of several program streams over a single FM frequency (e.g. HD1, HD2, etc.).
- clear, interference free reception.
- FM: CD quality sound.  
 AM: analog FM station sound quality.
- the display of text-based information (e.g. artist, track name) in the display

For further information on HD Radio™, visit <http://www.hdradio.com>.

### Switching wavebands

You can switch the radio waveband between FM, MW, WB and SatRadio.

Waveband	Frequency
FM (VHF)	87.7 – 107.9 MHz
MW (medium wave)	530 – 1710 kHz
WB (weather band)	Weather report channels
Satellite radio	Satellite radio stations

- ▶ Press the button once or several times.

### Selecting a station

#### Selecting stations via the station search function

- ▶ Press the button once or repeatedly until the **FM, AM, WB** or **SatRadio** waveband appears in the submenu bar.
- ▶ Slide or turn the controller when the display/selection window is active.

or

- ▶ Press the or button.

Station search scans up or down and stops at the next station, subprogram (HD Radio mode) or channel (SatRadio mode) found.

#### Selecting stations via the station presets

- ▶ **Quick setting:** press a number key, e.g.

.

- ▶ **Directly in the station presets:** select **Presets** by sliding and turning the controller and press to confirm.

or





- ▶ Press the controller when the display/selection window is active.

The station preset memory appears. The

- dot indicates under which preset the currently selected station is stored.

- ▶ Select a station by turning and pressing to confirm or press a number key, e.g. .

### Selecting stations by entering the frequency manually



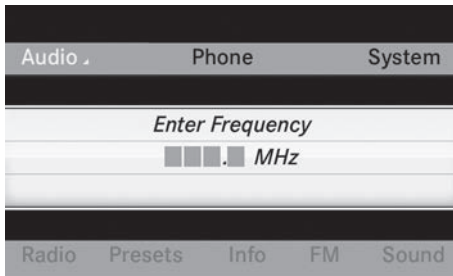

- ▶ Select **Radio** using the controller (slide ,  or turn ) and press  to confirm.
- ▶ Select **Enter Frequency** and press  to confirm.



P82.60-8177-31

- ▶ Only permissible numbers for the frequency range can be entered in front of the decimal point. If a non-permissible number is entered after the decimal point, the next lowest frequency is set.
- ▶ Press the number keys on the number keypad. Audio 20 tunes in to the frequency.

### Setting a station via the multifunction steering wheel

- ▶ In the audio menu in the instrument cluster: press the  or  button briefly. The next or the previous station from the station list is set.
- ▶ In the audio menu in the instrument cluster: press and hold the  or  button for longer than two seconds. The previous or next station/channel in the waveband will be set.





### Storing a station

#### Storing stations manually

Ten stations can be stored for each waveband.

- ▶ If a selected preset is already occupied, the new station will be stored in place of the old station.
- ▶ **Quick save:** when the display/selection window is active, press and hold a number key (0 to 9) on the number keypad until you hear a tone. The station is now stored on the selected preset.
- ▶ **Directly in the station presets:** press  the controller when the display/selection window is active.

or

- ▶ Select **Presets** using the controller (slide ,  or turn ) and press  to confirm. The station preset display appears. The
  - dot in front of a preset position indicates that the currently selected station is stored there.



P82.60-8204-31

#### Assigning a new preset:

- ▶ **Quick save:** press and hold a number key, e.g. , until you hear a tone. The station is stored.

- ▶ **Directly in the station presets:** press the controller when the display/selection window is active.

or

- ▶ Select **Presets** by sliding and turning the controller and press to confirm.

In both cases, the station presets appear. The dot indicates under which preset the currently selected station is stored.

- ▶ Select a preset by turning the controller and press and hold until you hear a tone. The station is stored under the preset.

### Storing stations automatically

This function automatically stores stations with adequate reception under the presets. The search starts at the lowest frequency. Audio 20 stores any stations found, beginning with preset 1. When the highest frequency is reached or 10 stations have been found, the storing process ends. Any stations stored manually under the presets will be lost. Under certain circumstances, Audio 20 will not use all presets.

If the process is interrupted by a traffic announcement, you must repeat it.

- ▶ Select **Presets** using the controller (slide , or turn ) and press to confirm.
- ▶ Select **Autostore** and press to confirm. Audio 20 searches for stations with adequate reception. The available stations are automatically stored in the preset positions. The first station found is played automatically.

### Weather Band

#### Activating

- ▶ Press the function button repeatedly until the Weather Band is switched on.

or

- ▶ Select the currently selected waveband **FM**, **AM** or **SatRadio** by sliding and turning the controller and press to confirm.
- ▶ Select **WB** from the menu and press to confirm.

#### Searching for a channel

- ▶ **Quick select:** turn or slide the controller while the display/selection window is active.

or

- ▶ Press the or button. Channel search scans up or down and stops at the next channel found.

#### Selecting a channel from the channel list

- ▶ Select **Channel1** by sliding and turning the controller and press to confirm. The channel list appears.
  - ▶ Select the channel by turning the controller and press to confirm.
- or
- ▶ Press a number key on the control panel, e.g. **4**, at any time.



### Displaying program information



P82.60-8217-31

Radio text: example display

This function is only available for analog FM programs and digital AM/FM programs (HD Radio™).

Information relevant to the current station is shown in the display window.

- ▶ Select **Info** in the radio display by sliding and turning the controller and press to confirm. Information on the currently selected station is displayed. Content is dependent on the station.
- ▶ **To return to the radio display:** confirm **Info** by pressing .
- ▶ Slide the controller up.

### Displaying station information

This function is only available for analog FM programs and digital AM/FM programs (HD Radio™).

- ▶ In the radio display slide and turn the controller to select **Radio** and press to confirm.
- ▶ Select **Show Station Information** and press to confirm. Depending on the previous status, you switch **Show Station Information** on  or off .

## Satellite radio

### Important notes

This section provides detailed information on the following topics:



- Selecting a channel and program category
  - Memory functions
  - Sound settings
- i** The SatRadio mode described below requires optional satellite radio equipment and registration with a satellite radio provider.

- i** Note that the categories and channels shown in the illustrations depend on the program content offered by the provider. The program content may vary. The illustrations and descriptions in these operating instructions may therefore differ from the channels and categories offered by the provider.

SatRadio mode may be temporarily interrupted or unavailable for a variety of reasons. These reasons include environmental or topographical conditions as well as other issues beyond the control of Mercedes-Benz USA, LLC. Operation may also be impaired in certain locations (e.g. tunnels, parking garages as well as inside or next to buildings) or in the vicinity of other constructions.

- i** SIRIUS XM Radio offers more than 130 digital-quality radio channels providing 100% commercial-free music, sport, news and entertainment. SIRIUS XM Radio employs a fleet of high-performance satellites to broadcast around the clock in the contiguous USA and Canada. The satellite radio program is available for a monthly fee. Details are available from the SIRIUS XM Service Center and at <http://www.sirius.com> (USA) or <http://www.siriuscanada.com> (Canada).

### Registering SatRadio

- ▶ Switch on SatRadio mode (▷ page 67).  
The SatRadio basic menu appears showing the weather channel. You cannot select any other stations.
- ▶ Select **Sat** in the menu bar and press  to confirm.
- ▶ Select **Service** and press  to confirm.  
The service information screen appears.



P82.60-8353-31

Service information screen

- ① Telephone number of the satellite radio provider (SIRIUS XM Radio)
  - ② SIRIUS XM ID of your satellite radio receiver
- ▶ Call the phone number of your satellite radio provider shown on the screen.
- i** You can also have the satellite service activated online. To do so, visit the SIRIUS XM Radio website at <http://www.sirius.com> (USA) or <http://www.siriuscanada.com> (Canada).

Once the connection has been established:





- ▶ Follow the instructions of the service staff.  
The activation process may take up to ten minutes. If the activation is successful, the **Updating Channels...** message appears in the display, followed by the SatRadio basic menu.
- i** If registration is not included when purchasing the system, your credit card

details will be required to activate your account.

If the satellite radio receiver is not installed or is not installed correctly, the **Device Unavailable** message will appear.

### Switching on satellite radio mode

#### Notes

You can also use the multifunction steering wheel to tune in channels or scroll through lists, e.g. by pressing the     buttons (▷ page 18).

For important notes on registration, see "Registering satellite radio" (▷ page 67).

- ▶ Press .  
The **No Service** message appears when starting up or if no signal is being received. Once Audio20 receives the signal, the SatRadio basic menu appears. The station last selected is played.

- i** Repeatedly pressing this function button switches through the wavebands in this order: FM, AM, WB and subsequently switches on the satellite radio. Pressing the button again takes you back to FM radio mode.

If the satellite radio receiver is not installed or is not installed correctly, the **Device Unavailable** message will appear.

Once Audio20 receives the signal, the SatRadio basic menu appears. The station last selected is played.

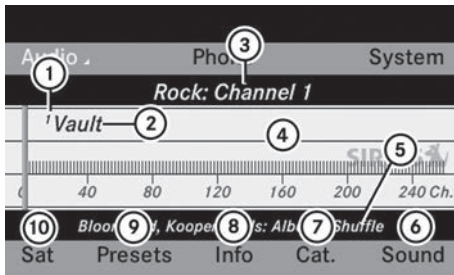

P82.60-8354-31

- ① Channel preset number
- ② Channel name
- ③ Selected category/channel number
- ④ Display/selection window
- ⑤ Channel information
- ⑥ Sound settings
- ⑦ To call up the category list
- ⑧ To show channel information (detailed) in the display/selection window
- ⑨ To call up the channel preset list
- ⑩ To call up the SatRadio menu

Channel information ⑧ can be viewed in detail (> page 69).

### Changing the category

Satellite radio channels are sorted into various categories. You can choose between the different categories, such as news/talk shows, sports or country, if they are available. The category list is sorted alphabetically.

#### Select category

- ▶ **To call up the category list:** select **Category** by turning  $\left[ \text{⏮} \right]$  the controller and press  $\text{⏵}$  to confirm. The category list appears.
- ▶ **To select a category:** select a category by turning  $\left[ \text{⏮} \right]$  the controller and press  $\text{⏵}$  to confirm. The category selected is shown in the display. You hear the station last selected for this category.

The **All Channels** category is at the top of the category list. This category is sorted by channel number and allows you to browse all available channels.

### Selecting a channel

#### Channel search

- ▶ When the display/selection window is active, turn  $\left[ \text{⏮} \right]$  or slide  $\leftarrow \text{⏵}$  the controller.

or

- ▶ Press the  $\left[ \text{⏮} \right]$  or  $\left[ \text{⏵} \right]$  button. Audio 20 searches in both directions (ascending and descending) and stops at the next channel found in the selected category.

#### SatRadio menu

- ▶ In the menu bar, select **Sat** by turning  $\left[ \text{⏮} \right]$  the controller and press  $\text{⏵}$  to confirm. The SatRadio menu appears.

### Entering channel numbers directly

#### Option 1

- ▶ Press  $\text{[*]}$ . An input menu appears.

#### Option 2:

- ▶ In the menu bar, select **Sat** by turning  $\left[ \text{⏮} \right]$  the controller and press  $\text{⏵}$  to confirm.
- ▶ Select **Enter Channel** and press  $\text{⏵}$  to confirm. An input menu appears.
- ▶ **To enter a channel:** irrespective of the option chosen, press the corresponding number keys on the control panel one after the other. Audio 20 sets the selected channel.

- i** You can only select currently permitted digits.

### Selecting a channel from the SatRadio channel list

You can call up two different channel lists:

- channel lists with a channel number and channel name
  - channel lists with additional information about the artist and track name on the current program, if transmitted with the program.
- ▶ In the menu bar, select **Sat** by turning **⏪** the controller and press **⏩** to confirm.
- ▶ Select **Channel List** or **Channel List with Artist, Title** and press **⏩** to confirm.  
The selected channel list appears.
- ▶ Select the channel by turning **⏪** the controller and press **⏩** to confirm.

### Memory functions

#### Storing channels

- i** There are ten presets available.
- ▶ Press **⏩** the controller when the display/selection window is active.
- or
- ▶ In the menu bar, select **Presets** by turning **⏪** the controller and press **⏩** to confirm.  
In both cases, the channel presets appear. The **•** dot in front of a preset entry indicates that the currently selected channel is stored under this preset.

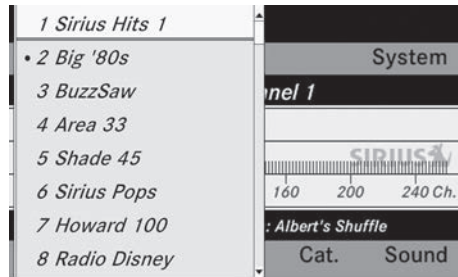

P82.60-8355-31

Channel presets

- ▶ Select a preset by turning **⏪** the controller, then press and hold **⏩** until a tone sounds.

or

- ▶ Press and hold a number button, e.g. **4**, until you hear a tone.  
The current channel is stored under the preset.

### Selecting a channel from the preset list

- ▶ **To call up the preset list:** in the menu bar, select **Presets** by turning **⏪** the controller, then press **⏩** to confirm.  
The channel preset list appears.
- ▶ **To set a channel:** select a preset by turning **⏪** the controller and press **⏩** to confirm.

or

- ▶ Press a number key, such as **4**.

### Displaying information

- ▶ In the menu bar, select **Info** by turning **⏪** the controller and press **⏩** to confirm.  
Information on the currently received program is displayed.

If available, you see:

- the full name
- additional information

- ▶ **To return to the SatRadio basic menu:** slide ←⊙→ the controller.

### Displaying service information

The provider's customer service center is available by phone at any time to answer any general questions or questions on the versions available.

- ▶ In the menu bar, select **Sat** by turning **⏪⊙⏩** the controller and press **⏵** to confirm.
- ▶ Select **Service** and press **⏵** to confirm. The provider's details appear.



P82.60-8353-31

Service information screen

- ① Telephone number of the satellite radio provider (SIRIUS XM Radio)
  - ② SIRIUS XM ID of your satellite radio receiver
- ▶ **To return to the SatRadio basic menu:** slide ←⊙→ the controller.

### Channel list updates

When receiving a new channel list, the display shows the **Updating Channels...** message.

The station last selected is switched to mute until the update has been completed. SatRadio mode is not available during this process.

Once the update has been completed, the SatRadio basic menu appears. The station last selected is played.

### Sound settings

You will find details on the sound settings in the "At a glance" section (▶ page 21).

### Audio CD and MP3 mode

#### Important safety notes

##### WARNING

The CD/DVD drive is a class 1 laser product. If you open the CD/DVD drive housing, you could be exposed to invisible laser radiation. This laser radiation could damage your retina. There is a risk of injury.

Never open the housing. Always have maintenance and repair work carried out at a qualified specialist workshop.

##### WARNING

Handling discs while driving may distract you from traffic conditions. You could also lose control of the vehicle. There is a risk of an accident.

Handle discs only when the vehicle is stationary.

Bear in mind that at a speed of just 30 mph (approximately 50 km/h), your vehicle is covering a distance of 44 feet (approximately 14 m) every second.

Audio 20 is equipped with a single CD drive. The drive can play back audio CDs and MP3 CDs. The settings available in the menu may vary depending on the type of disc.

## Inserting and removing CDs

### Notes

If the CD has a printed side, this must face upwards when the CD is inserted. If neither side is printed, the side to be played should face downwards. The system may not be able to play discs with copy protection.

- i** If a medium contains other files in addition to music files, the loading time before the first track starts to play may be longer.

### Inserting a disc into the single CD drive

- ▶ Press the  eject button.  
If there is a disc already inserted, it will be ejected.
- ▶ Take the disc out of the slot.
- ▶ Insert a disc into the slot.  
If a suitable data medium is correctly inserted, the drive draws it in and plays it.

### Removing a disc from the single CD drive

- ▶ Press the  eject button.
- ▶ Take the disc out of the slot.  
If you do not remove the disc from the slot, Audio 20 will draw it in again automatically after a short time and reload it.

## Connecting a USB device

The USB port is located under the center console armrest.

Electrical consumption at this connection must not exceed a continuous current of 500 mA. If the electrical consumption is higher, use a separate source to provide power for the USB device (e.g. 12 V power supply).

The following data formats are supported:

- AAC, M4A: fixed and variable bit rates (Low Complexity Profile)
- MP3, WMA: fixed and variable bit rates up to 320 kbit/s
- ▶ Connect the USB device (e.g. USB stick) to the USB port.

## Switching to audio CD or MP3 mode

### Option 1

- ▶ Insert the CD (▷ page 71) or connect the USB device (▷ page 71).  
Audio 20 loads the inserted medium and playback starts.

### Option 2:





- ▶ Press the  function button one or more times.

- i** By pressing the function button repeatedly, you can change the operating mode in the following order:

- Audio CD/MP3 (disc)
- USB storage device
- Operation with the Media Interface
- Bluetooth® audio mode
- Audio AUX

- ▶ Select an audio medium from the media list.

### Option 3

- ▶ Select **Audio** from the main function bar using the controller (slide   and turn  and press  to confirm.  
The last active audio source is now activated.  
You can activate a different audio source using the audio menu.

- ▶ Select **Audio** using the controller (slide  $\uparrow$   $\odot$  and turn  $\left\langle \odot \right\rangle$ ) and press  $\odot$  to confirm.  
The audio menu appears.
- ▶ Select **Disc**, **USB Storage**, **Media Interface** or **Bluetooth® Audio** and press  $\odot$  to confirm.  
This switches to the desired audio source.
- ▶ Select an audio medium from the media list ( $\triangleright$  page 72).

### Example display: audio CD mode

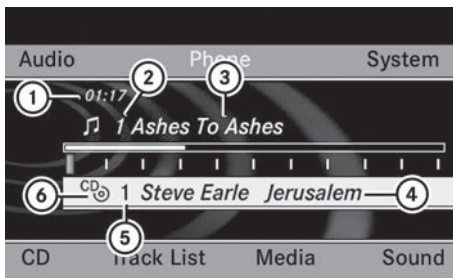

P82.60-8212-31

- ① Track time
  - ② Track number
  - ③ Track name (only if stored on the disc)
  - ④ Disc name (only if stored on the disc as CD text)
  - ⑤ Data carrier position in the media list
  - ⑥ Type of data medium
- i** The artist may appear below ④ if this information is available.

### Example display: MP3 mode



P82.60-8362-31

- ① Cover (if available)
  - ② Track time
  - ③ Track number and name
  - ④ Graphic time and track display
  - ⑤ Medium type, position of medium in the media list, current folder
  - ⑥ Artist (if available)
  - ⑦ Basic MP3 mode menu
- i** Cover display ① is only available for MP3 files accessed via a USB storage device.

### Pause function

- ▶ **To pause playback:** briefly press the  $\square$  button.  
The  $\boxtimes$  symbol appears at the top left in the status bar.
- ▶ **To continue playback:** briefly press the  $\square$  button again.  
The  $\boxtimes$  symbol disappears.

### Selecting an audio CD or MP3 disc

#### Selecting via the media list

- ▶ **In Audio CD and MP3 mode:** select **Media** using the controller (slide  $\odot$   $\downarrow$  and turn  $\left\langle \odot \right\rangle$ ) and press  $\odot$  to confirm.  
The media list appears. The  $\bullet$  dot indicates the current medium being played.

The media list shows the discs currently available.



### Media list

Magazine tray, position 1: readable data media are audio CDs or MP3 CDs

USB, position 2

Media Interface, position 3

Bluetooth® audio, position 4

**i** If a disc cannot be read, an entry appears next to the corresponding magazine tray.

- ▶ Select a medium by turning **⏪** or **⏩** the controller and press **⏵** to confirm.

### Selecting a track using the number keypad

- ▶ When the display/selection window is active, press a number key, e.g. the **4** GHI key.

The medium at the corresponding position in the media list is loaded and then played.

### Select track

#### Selecting by skipping to a track

- ▶ **To jump forwards or backwards to a track:** turn **⏪** or **⏩** the controller when the display/selection window is active.

or

- ▶ Press the **⏮** or **⏭** button.  
The skip forward function skips to the next track.

The skip back function skips to the beginning of the current track if the track has been playing for more than eight seconds. If the track has been playing for less than eight seconds, it skips to the start of the previous track.

If the **Random Tracks** or **Random Folder** playback option has been selected, the track order is random.

- ▶ **On the multifunction steering wheel:** switch to audio CD or MP3 mode on the Audio 20 system (▷ page 71).
- ▶ Press the **⏮** or **⏭** button to select the **Audio** menu.



- ① Track display

- ▶ Press the **▲** or **▼** button briefly.
- ▶ Press and hold the **▲** or **▼** button until the desired track has been reached.

If you press and hold the **▲** or **▼** button, the rapid scrolling speed is increased. Not all audio drives or data carriers support this function.

If track information is stored on the audio device or medium, the multifunction display will show the number and name of the track.

#### Selecting a track using the number keypad

- ▶ Press the **\*+** key on the number keypad. A numerical entry field appears. The number of positions offered corresponds to the number of tracks on the CD. Only numbers that correspond to a track number on the CD can be entered.
- ▶ Enter the desired track number using the number keys.  
The track plays after the last possible number is entered.

- i** Pressing and holding a number key for more than two seconds completes the entry, and the corresponding track is played.



### Selecting by track list

#### Calling up the track list

##### Option 1

- ▶ Press the controller when the display/selection window is active.

##### Option 2:

- ▶ In audio CD, MP3 or USB audio mode, select **Track List**, **Folder** or **Music** using the controller (slide and turn ) and press to confirm.

The track list appears. The dot indicates the current track.

#### Selecting a track

- ▶ Select the desired track by turning the controller and press to confirm. The track is played.

### Selecting a folder

- This function is only available in MP3 mode (CD and USB).

- ▶ Select **Folder** or **Music** from the menu bar by sliding the controller and press to confirm.

or

- ▶ Press the controller when the display/selection window is active.

The folder list appears.

- ▶ Select the desired folder by turning the controller and press to confirm. You will see the tracks in the folder.
- ▶ Select a track and press to confirm. The track is played.

### Fast forwarding/rewinding

- ▶ Slide the controller to select the display/selection window.
  - ▶ Slide the controller and hold it until the desired position has been reached.
- or
- ▶ Press and hold the or button.

### Displaying metadata (MP3 mode)

When playing MP3 files, Audio 20 can also display the name of the album and the artist (metadata). This is only possible if the metadata has been previously entered into the system.

For USB devices, you can choose whether to display the file name and folder during playback.





- If the metadata characters are not displayed correctly, the **Display Track Information** option should be deactivated.

- ▶ **To display the album and artist name:** select **MP3** or **USB Storage** in the basic display using the controller (slide and turn ) and press to confirm.
- ▶ Select **Display Track Information** and press to confirm. This switches the track information display on  or off .

### Selecting an active partition (USB mass storage devices only)



You can select this function for USB mass storage devices when the storage device is partitioned. Up to four partitions (primary or logical; FAT format) are supported.

- The Windows formatting program supports FAT partitions of up to 32 GB as standard.

- ▶ Select **USB Storage** using the controller (slide  and ) and press  to confirm.
- ▶ Select **Select Active Partition** and press  to confirm.

### Playback option

The following options are available to you:

- **Normal Track Sequence**  
The tracks are played in the normal order (e.g. 1, 2, 3, etc.).
  - **Random Tracks**  
The tracks are played in random order (e.g. 3, 8, 5 etc.).
  - **Random Folder** (only in MP3 mode)  
The tracks in the currently active folder are played in random order.
  - ▶ **To select an option:** select **CD/MP3**.  
The options list appears. The  dot indicates the option selected.
  - ▶ Select an option.  
The option is switched on. For all options except **Normal Track Sequence**, a corresponding display will appear in the main area.
-  The **Normal Track Sequence** option is automatically selected when you change the disc you are currently listening to or when you select a different medium. If an option is selected, it remains selected after Audio 20 is switched on or off.

### Notes on MP3 mode

#### General notes

-  Depending on the volume and format of the MP3 data, the length of time required for reading the data may increase.

#### Permissible data carriers

- CD-R and CD-RW
- USB storage device

#### Permissible file systems

- ISO 9660/Joliet standard for CDs
- FAT16 or FAT32 for USB storage media

#### Multisession CDs

For multisession CDs, the content of the first session determines how Audio 20 will process the CD. Audio 20 plays only one session and gives priority to the audio CD session.

If possible, use Audio 20 to play only CDs that have been written in one session.

#### File structure of a data carrier

When you create a disc with compressed music files, the tracks can be organized in folders. A folder may also contain subfolders. A disc can contain a maximum of 255 folders. Each folder can contain a maximum of 255 tracks and 255 subfolders. A maximum of 512 files are permitted on an MP3 CD. The disc may contain no more than eight directory levels. Files beyond the eighth level will not be recognized by the system.

#### Track and file names

Audio 20 does not support ID3 tags. Music files can contain meta information such as artist, album or track names. Audio 20 displays this information during playback. When you create a disc with compressed music files, you can assign names to the tracks and folders. Audio 20 displays these names if no meta information is available. If MP3 or WMA files are stored in the root directory itself, the root directory will also be treated as a folder. Audio 20 will then show the name of the root directory as the folder name.

You must observe the following when assigning track names:

- track names must have at least one character.
- track names must have the extension "mp3" or "wma".
- there must be a dot between the track name and the extension.

Example of a correct track name:  
"Track 1.mp3".

### Permissible formats

Audio 20 supports the following formats:

- MPEG1 Audio Layer 3 (MP3)
- Microsoft Windows Media Audio V2, V7, V8 and V9 (WMA)
- music files in AAC format with the aac and m4a extension, but not copy-protected iTunes music files with the extension m4p.

**i** If, in addition to MP3 files, there are other music files in these audio formats stored on the disc, the loading process may require a longer time before the first track is played.

**i** The MP3 audio encoding method is under license from Fraunhofer IIS (Institut Integrierte Schaltungen – Institute for Integrated Circuits) and Thomson.

### Permissible bit and sampling rates

Audio 20 supports the following types of **MP3** files:

- fixed and variable bit rates from 32 kbit/s to 320 kbit/s
- sampling rates of 8 kHz to 48 kHz

Audio 20 supports the following types of **WMA** files:

- fixed bit rates from 5 kbit/s to 384 kbit/s
- sampling rates of 8 kHz to 48 kHz

Audio 20 does **not** support the following types of **WMA** files:

- DRM (Digital Rights Management) encrypted files
- variable bit rate
- WMA Pro
- 5.1 Surround

**i** Only use tracks with a bit rate of at least 128 kbit/s and a sampling rate of at least 44.1 kHz. Lower rates can cause a noticeable deterioration in quality. This is especially the case if you have activated a surround sound function.

### Notes on copyright

MP3 or WMA tracks that you create or play back are generally subject to copyright protection in accordance with the applicable international and national regulations.

In many countries, reproductions, even for private use, are not permitted without the prior consent of the copyright holder.

Make sure that you know about the applicable copyright regulations and that you comply with these.

If you own these rights yourself, e.g. for your own compositions and recordings, or if the copyright holder has granted you permission, these restrictions do not apply.

### Notes on compact discs

**i** Discs with copy protection are not compatible with the audio CD standard. Consequently, it may not be possible to play them on the Audio 20 system.

Playback problems may occur when playing copied discs. A wide range of data media, burning software and burners is available. This variety means that there is no guarantee that the system will be able to play discs that you have copied yourself.

There may be playback problems if you play CDs that you have copied yourself with a storage capacity of more than 700 MB. CDs

of this type do not conform to the currently applicable standards.

- !** Do not affix stickers or labels to the discs. They could peel off and damage the drive. The drive is designed to hold discs which comply with the EN 60908 standard. Therefore, you can only use discs with a maximum thickness of 1.3 mm. If you insert thicker discs, e.g. those that contain data on both sides (DVD on one side and audio data on the other), they cannot be ejected and can damage the drive.

Do not use discs with a diameter of 8 cm, even with an adapter. Only use round discs with a diameter of 12 cm.

## Bluetooth® audio

### Preconditions for the Bluetooth® audio device

Bluetooth® audio mode requires a Bluetooth®-capable audio device. Observe the information in the Bluetooth® audio device's operating instructions.

Before using Bluetooth® audio mode, you should check your Bluetooth® audio device for the following:

- Bluetooth® audio profile  
The Bluetooth® audio device must support the A2DP and AVRCP Bluetooth® audio profiles.
- Bluetooth® visibility  
Certain Bluetooth® audio devices do not just require activation of the Bluetooth® function. In addition, your device must be made "visible" to other devices.
- Bluetooth® device name  
This device name is predetermined but can usually be changed. To make a clear selection of the Bluetooth® device possible, Mercedes-Benz recommends that you customize the device name.

- i** A2DP (**A**dvanced **A**udio **D**istribution **P**rofile): Bluetooth® audio profile for audio data transmission  
AVRCP (**A**udio **V**ideo **R**emote **C**ontrol **P**rofile): Bluetooth® audio profile for audio data playback

- i** Not all Bluetooth® audio devices available on the market are equally suitable. For more detailed information on suitable Bluetooth® audio devices and on connecting Bluetooth® audio devices to Audio 20, visit <http://www.mbusa-mobile.com>. Or call the Mercedes-Benz Customer Assistance Center at 1-800-FOR-MERCEdes(1-800-367-6372) (for the USA) or Customer Relations at 1-800-387-0100 (for Canada).

### Preconditions for Audio 20

- Bluetooth® must be activated in Audio 20 (▷ page 32).

### Connecting a Bluetooth® device

#### General information

Before using your Bluetooth® audio device with Audio 20 for the first time, you will need to authorize it.

When you authorize a new Bluetooth® audio device, it is connected automatically.

Connecting comprises:

- searching for a Bluetooth® audio device
- subsequently authorizing it

You can connect up to 15 Bluetooth® devices.

- i** If you authorize a mobile phone that supports Bluetooth® audio, it is entered in the Bluetooth® phone list (▷ page 44) as well as in the Bluetooth® device list. Mercedes-Benz recommends authorizing a

mobile phone in Bluetooth® telephony  
(▷ page 45).

### Searching for and authorizing a Bluetooth® audio device

- ▶ Switch on Bluetooth® audio mode  
(▷ page 80).  
If you see the **No Bluetooth Audio Device Authorized** message, you will need to authorize the Bluetooth® audio device first.
- ▶ Select **BT Audio** by sliding  $\odot \downarrow$  and turning  $\left[ \odot \right]$  the controller and press  $\odot$  to confirm.
- ▶ Select **Bluetooth Audio Device List** and press  $\odot$  to confirm.

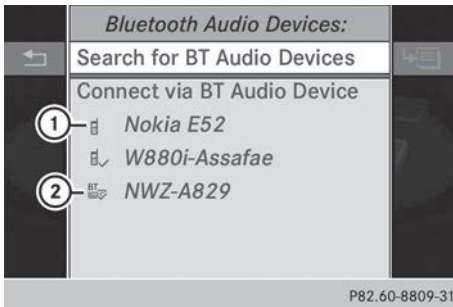

Example: Bluetooth® device list

- ① Newly detected mobile phone with Bluetooth® audio function in range
  - ② Bluetooth® audio player not within range but previously authorized (symbol appears in gray)
- ▶ **To search:** select **Search for BT Audio Devices** and press  $\odot$  to confirm.  
Audio 20 searches for Bluetooth® audio devices within range and adds them to the Bluetooth® device list. For this purpose, the devices must support the A2DP and AVRCP Bluetooth® audio profiles.  
The duration of the search depends on the number of Bluetooth® audio devices within range and their characteristics.



- ▶ **To authorize:** select a Bluetooth® audio device that has not yet been authorized from the list by turning  $\left[ \odot \right]$  the controller.
- ▶ Select the symbol to the right of the Bluetooth® audio device by sliding  $\odot \rightarrow$  the controller and press  $\odot$  to confirm.
- ▶ Select **Authorize** and press  $\odot$  to confirm.  
Depending on the Bluetooth® audio device used, you now have two options for continuing with authorization.
- ▶ **Option 1:** enter the passkey (▷ page 45).  
After successful authorization, the Bluetooth® audio device is connected and starts playing.
- ▶ **Option 2 (Secure Simple Pairing):** if the digit codes displayed on Audio20 and on the Bluetooth® audio device are the same, confirm **Yes** by pressing  $\odot$ .  
If you select **Yes**, authorization continues and the Bluetooth® audio device is connected. Playback starts.  
If you select **No**, authorization will be canceled.

**i** The Bluetooth® audio device must support Bluetooth® version 2.1 for connection via Secure Simple Pairing. Audio 20 creates a six-digit code, which is displayed on both devices that are to be connected.

### External authorization

If Audio 20 does not find your Bluetooth® audio device, this may be due to particular security settings on your Bluetooth® audio device. In this case, check whether your Bluetooth® audio device can locate the Audio 20 system. The Bluetooth® device name of Audio 20 is **MB Bluetooth**.

- ▶ Switch on Bluetooth® audio mode .
- ▶ Select **BT Audio** by sliding  $\odot \downarrow$  and turning  $\left[ \odot \right]$  the controller and press  $\odot$  to confirm.

- ▶ Confirm **Bluetooth Device List** by pressing  the controller.
  - ▶ **To search:** confirm **Search for BT Audio Devices** by pressing  the controller.  
The duration of the search depends on the number of Bluetooth® audio devices within range and their characteristics.
  - ▶ **To authorize:** start the authorization on the Bluetooth® audio device, see the operating instructions of the Bluetooth® audio device.  
After successful authorization, the Bluetooth® audio device is connected and starts playing.
- i** With some Bluetooth® audio devices, playback must be initially started on the device itself so that Audio 20 can play the audio data.

### Reconnecting a Bluetooth® audio device

The Bluetooth® audio profiles are connected automatically under the following circumstances:

- one of the last two mobile phones to have been connected has also been used as a Bluetooth® audio player (if this function is supported by the mobile phone).
- the mobile phone takes over the automatic connection itself.

A Bluetooth® audio player without telephone functions is not automatically reconnected, even if it was the last device connected.





If the **No Bluetooth Audio Device Connected** message appears, you have the following options to connect a Bluetooth® audio device:

#### Option 1

- ▶ Confirm **Connect Last Device** in the basic display by pressing  the controller.  
If Audio 20 can locate the Bluetooth® audio device, it will be connected and playback will start.

- i** With some Bluetooth® audio devices, playback must be initially started on the device itself so that Audio 20 can play the audio data.

#### Option 2:



- ▶ Select **BT audio** by turning  the controller and press  to confirm.
- ▶ Select **Bluetooth Device List** and confirm by pressing  the controller.
- ▶ Select a Bluetooth® audio device by turning  the controller and press  to confirm.  
If Audio 20 can locate the Bluetooth® audio device, it will be connected and playback will start.



- i** With some Bluetooth® audio devices, playback must be initially started on the device itself so that Audio 20 can play the audio data.

### Bluetooth® audio device and simultaneous search for mobile phones

During the search for mobile phones, the connection with the Bluetooth® audio device is terminated. In the Bluetooth® audio basic display, you will see the **No Bluetooth Audio Device Connected** message and the **Connect Last Device** menu item cannot be selected.



#### Displaying details

- ▶ Select a Bluetooth® audio device in the Bluetooth® device list.
- ▶ Select the symbol to the right of the Bluetooth® audio device by sliding  the controller and press  to confirm.

- ▶ Select **Details** and press  to confirm. The following information concerning the selected mobile phone is shown:
  - Bluetooth® name
  - Bluetooth® address
  - availability status (shown after a new search)
  - authorization status
- ▶ **To close the detailed view:** turn  or slide  the controller.

### De-authorizing (deregistering) a Bluetooth® audio device

#### Audio

- ▶ Select a Bluetooth® audio device in the Bluetooth® device list.
  - ▶ Select the symbol to the right of the Bluetooth® audio device by sliding  the controller and press  to confirm.
  - ▶ Select **De-Authorize** and press  to confirm. A prompt appears asking whether you really wish to de-authorize this device.
  - ▶ Select **Yes** or **No**. If you select **Yes**, the device will be deleted from the Bluetooth® device list. If you select **No**, the process will be canceled.
- i** Before re-authorizing the Bluetooth® audio device, you should also delete the device name **MB Bluetooth** from your Bluetooth® audio device's Bluetooth® list.

### Switching to Bluetooth® audio mode



#### By connecting a Bluetooth® audio device

- ▶ Connect (▷ page 77) or reconnect (▷ page 79) a Bluetooth® audio device. Audio 20 activates the Bluetooth® audio device. The basic display appears and the device starts playing.

### Using the function button

- ▶ Press the **DISC** function button one or more times.
  - i** By pressing the function button repeatedly, you can change the operating mode in the following order:
    - Audio CD/MP3 (disc)
    - USB storage media
    - Operation with the Media Interface
    - Bluetooth® audio mode
    - Audio AUX

### Using the media list

- ▶ Select **Bluetooth Audio** in the media list by turning  the controller and press  to confirm (▷ page 72). Audio 20 activates the connected device. You will see a message to this effect. The basic display then appears.
  - i** If the Bluetooth® audio device connected supports metadata and corresponding data is available, then the artist, track and album name can be displayed.

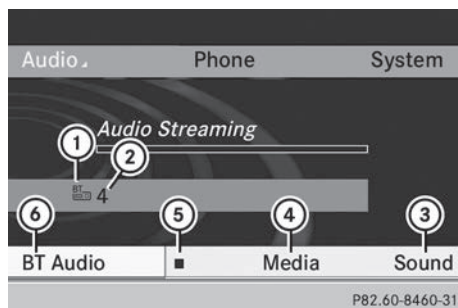

### Bluetooth® audio basic display















Example: Bluetooth® audio display

- ① Bluetooth® audio data medium type
- ② Position in the media list
- ③ Sound settings
- ④ Media list



- ⑤ To stop  or start  playback
- ⑥ To connect Bluetooth® audio devices

### Starting/stopping playback

- ▶ **To start playback:** select  using the controller (slide  and turn ) and press  to confirm.  
Playback starts.  is selected.
- ▶ **To stop playback:** select  by turning  the controller and press  to confirm.  
A message appears.  is selected.
- ▶ **To resume playback:** select  by turning  the controller and press  to confirm.  
A message appears.  is selected.



### Starting playback if the Bluetooth® audio device has been stopped

During the search for mobile phones (> page 44), the connection with the Bluetooth® audio device is terminated. In the Bluetooth® audio basic display (> page 48), you will see the **No Bluetooth Audio Device Connected** message and the **Connect Last Device** menu item cannot be selected while the system is searching for mobile phones.

When the search is finished, the Bluetooth® audio device can be reconnected.



- ▶ Confirm **Connect Last Device** by pressing .
- Depending on the Bluetooth® audio device used, playback starts immediately or you must start playback manually.  
In this case, you will see the **Bluetooth Audio Device Paused** message.







- ▶ **To start playback:** select  by turning  the controller and press  to confirm.  
Playback resumes from the beginning.



### Select track

The function is not supported by all Bluetooth® audio devices.

- ▶ **To skip forwards or backwards to a track:** press the  or  button.

or

- ▶ Press the  or  button briefly on the multifunction steering wheel.
- ▶ **Rapid scroll:** press and hold the  or  button on the multifunction steering wheel until the desired track is reached.

If you press and hold the  or  button, the rapid scrolling speed is increased.

### Selecting playback options

If the Bluetooth® audio device supports the corresponding function, the following options are available:

- **Normal Track Sequence**

The tracks are played in the normal order (e.g. track 1, 2, 3, etc.).

Audio data playback is determined by the order in which the tracks are written to the data carrier. Alphabetical order is the most common. Once all the tracks in a folder



have been played, the tracks in the next folder are played.

- **Random Tracks**

All the tracks on the medium are played in random order (e.g. track 3, 8, 5 etc.).

- ▶ Select **BT Audio** by sliding  $\odot \downarrow$  and turning  $\left[ \odot \right]$  the controller and press  $\odot$  to confirm.

The  $\bullet$  dot indicates the option selected.

- ▶ Select an option by turning  $\left[ \odot \right]$  the controller and press  $\odot$  to confirm.

If you select **Random Tracks**, you will see a corresponding symbol in the display/selection window.

### Adjusting the sound settings

A description of the sound settings using radio mode as an example can be found under "Basic functions of Audio 20" ( $\triangleright$  page 21).

### Increasing the Audio 20 volume

- ▶ Select **BT Audio** using the controller (slide  $\odot \downarrow$  and turn  $\left[ \odot \right]$ ) and press  $\odot$  to confirm.
- ▶ Select **Volume** and press  $\odot$  to confirm.  
A menu appears. The  $\bullet$  dot indicates the current setting.

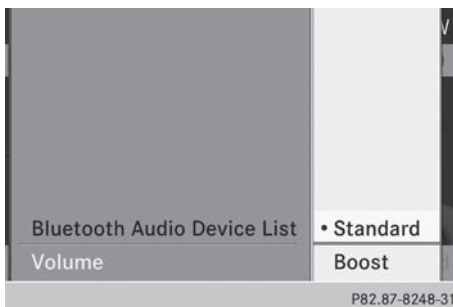

- ▶ Select **Standard** or **Boost** and press  $\odot$  to confirm.

You will find further information in the "Audio AUX mode" section ( $\triangleright$  page 87).

## Operation with the Media Interface

### Important safety notes

#### **WARNING**

If you handle or operate mobile audio/video sources when driving, you will be distracted from the traffic conditions. You could also lose control of the vehicle. There is a risk of an accident.

Only handle or operate these mobile audio/video sources when the vehicle is stationary.

Only operate mobile audio/video sources using the communication equipment integrated in the vehicle when traffic conditions permit. If you are not sure that this is possible, park the vehicle, paying attention to traffic conditions, and operate the equipment when the vehicle is stationary.

### Connection options

#### Overview

You will find the connection sockets in the center console stowage compartment.

Device-specific adapter cables are required to connect external devices to the Media Interface. Country-specific versions are supplied with the Media Interface.

- Store individual parts in a safe place.  
Only use genuine Mercedes-Benz connection cables.

The Media Interface allows you to connect the following devices to Audio 20:

- iPod®
- iPhone®
- certain MP3 players
- iPod® and iPhone® are registered trademarks of Apple Inc., Cupertino, California, USA.
- MP3 players that support MTP (Media Transfer Protocol) can be used. This allows the MP3 player to be easily connected to

the Media Interface and removed after use. Audio data is played without problem. On some MP3 players, you have to activate the relevant function; see the MP3 player operating instructions.

### Supported devices

For further details and a list of supported devices, please visit

<http://www.mbusa-mobile.com>

(customers in the USA only). Then follow the instructions in the "Media Interface" section. You can also call Mercedes-Benz Customer Service at 1-800-FOR-MERCEdes(1-800-367-6372) (US), or Customer Relations at 1-800-387-0100 (Canada).

### Connecting an external device

**i** Do not leave external devices in the vehicle as extreme temperatures (e.g. direct sunlight or extremely low outside temperatures) could cause them to malfunction (see the operating instructions for the respective device). Mercedes-Benz accepts no liability for damage to external devices.

Never connect more than one device at a time. You will otherwise not be able to play back from the external device. Please consult an authorized Mercedes-Benz Center for further information.

USB hubs (devices with several USB connections) are not supported.

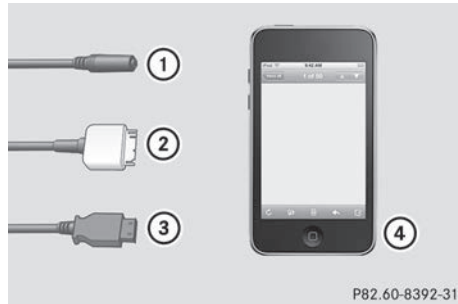

- ① Socket for 3.5 mm jack plug, e.g. for MP3 players
- ② iPod® plug, to connect an iPod®
- ③ USB socket for connecting an MP3 player
- ④ Example of device: iPod®

▶ Connect the external device with suitable socket ①, ② or ③.

Audio 20 activates the device. If connected via the iPod® connector or USB socket, a message appears.

If you remove a device, the **No Device Connected** message appears.

**i** A connected iPod® or MP3 player should not be simultaneously operated via the Media Interface and the remote control (e.g. Bluetooth® remote control) or directly via the device itself. Doing so may cause unforeseen technical difficulties.

Applications (Apps) that are activated on the connected device may lead to malfunctions.

**i** Connecting a fully discharged iPod® or MP3 player can result in an extended initialization period.

Error messages appear while the device is being activated if:

- Audio 20 does not support the device connected (**External Device Unavailable** message).
- the connected device consumes too much power.

- the Media Interface connection is faulty.
- a mass storage device (such as a USB stick or USB hard drive) is connected to the Media Interface (**Please connect the device to the other USB port** message).

**i** The separate USB connection ensures quick access and expanded media content options.

Consult an authorized Mercedes-Benz Center if required.

### Switching to Media Interface mode

#### General notes

**i** In extreme cases, starting up individual functions can take up to several minutes. This depends on the external device and the nature of the stored data (e.g. video podcasts).

Only use the original software to save files on your iPod® or MP3 player. Otherwise, some or all functions may not be available.

#### Option 1

- ▶ Connect an external device (▷ page 83). Audio 20 activates the device. If connected via the iPod® connector or USB socket, a message appears. The basic display then appears.

#### Option 2:

- ▶ Press the **DISC** function button one or more times.

By pressing the function button repeatedly, you can change the operating mode in the following order:

- Audio CD/MP3 (disc)
- USB storage device
- Operation with the Media Interface
- Bluetooth® audio mode
- Audio AUX

#### Option 3

- ▶ Press number key **3 DEF** (single CD drive). This selects the connected external audio device directly.

#### Option 4

- ▶ In the media list, turn **⏪** the controller to select the entry under position 3 (single CD drive) and press **⏹** to confirm.

Audio 20 activates the connected device. You will see a message to this effect. The basic display then appears.

If no device is connected, you will see the **Media Interface** entry instead of a device name.

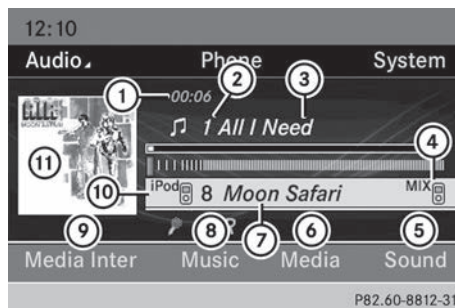

Example iPod® display

- ① Track time
- ② Track number
- ③ Track name
- ④ Current playback option
- ⑤ Sound settings
- ⑥ Media list
- ⑦ Album name (if available)
- ⑧ Categories, playlists and/or folders
- ⑨ Playback options
- ⑩ Type of data medium
- ⑪ Cover (if available)

The type of data medium connected **⑩** is indicated by the corresponding iPod® or MP3 player symbol.

Symbol ④ displays the current playback option (not displayed in **Normal Track Sequence** mode).

- i** If the device connected does not contain any playable tracks, a message appears to this effect.

### Selecting music files

#### Note

- i** Audio 20 displays the files stored on the iPod®, iPhone® or MP3 player according to the file structure on the respective medium.

### Selecting by skipping to a track

- ▶ **To skip forward or back to a track:** slide ◀⊙▶ or turn [⊙] the controller when the display/selection window is active.

or

- ▶ Press the [▶▶] or [◀◀] button.

The skip forward function skips to the next track. The skip back function skips to the beginning of the current track if the track has been playing for more than eight seconds. If the track has been playing for less than eight seconds, it skips to the start of the previous track. If a playback option other than **Normal Track Sequence** is selected, the track sequence is random.

- ▶ **On the multifunction steering wheel:** switch on Media Interface mode on the Audio 20 system (> page 84).
- ▶ Press the [◀] or [▶] button on the multifunction steering wheel to select the **Audio** menu.
- ▶ Press the [▲] or [▼] button briefly. If you hold down the [▲] or [▼] button, the system scrolls through the list more quickly. Not all media players support this function.

If track information is available on the media player, the multifunction display shows the number and name of the track.

### Selecting using the number keypad

- ▶ **To make an entry:** press the [✳] button. An input menu appears. The number of characters available for input depends on the number of stored tracks.

- ▶ **To enter a track number:** press a number key, e.g. [7] POS. The digit is entered in the first position in the input line.

- i** Audio 20 will ignore and not display an invalid digit.

- ▶ Enter more numbers if desired. The track plays after the last possible number is entered.

- i** Pressing and holding a number key for more than two seconds completes the entry, and the corresponding track is played.

### Fast forwarding/rewinding

- ▶ While the display/selection window is active: slide ◀⊙▶ and hold the controller until the desired position is reached.

or

- ▶ Press and hold the [◀◀] or [▶▶] button until the desired position is reached.

- i** On an iPod® or iPhone®, fast rewind only functions within the current track.

### Selecting a category/playlist/folder

#### iPod® and certain MP3 players

For an iPod®, iPhone® or MP3 player, you can select tracks using categories or folders.

Depending on the device connected, the following categories may be available, for example:





- **Current Tracklist**
- **Playlists** (e.g. **All** or "My Top 25")
- **Artists**
- **Albums**
- **Tracks**
- **Podcasts**
- **Genres**
- **Composers**
- **Audiobooks**

**i** Some playback categories contain the entry **All**. If this entry has been selected, the entire content of the category selected will be played.

#### Calling up a category list

► **To open a category list/folder:** press  the controller when the display/selection window is active.

or

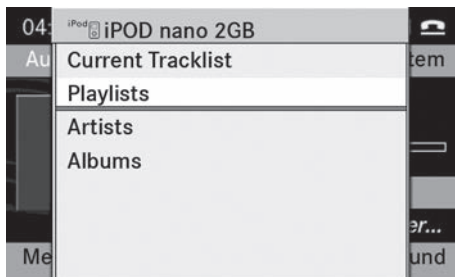

► Select **Music** from the basic display using the controller (slide   or turn ) and press  to confirm.  
The category list appears.

**i** The **Music** menu item is not available until the device has been activated.



P82.60-8243-31

Example: category list

► Select **Current Tracklist** by turning  the controller and press  to confirm.  
The content of the current track list appears.

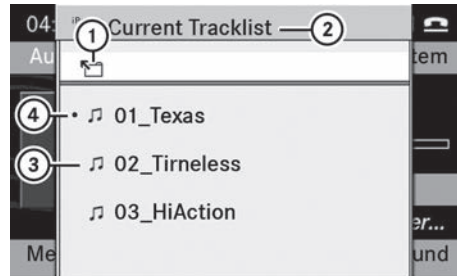

P82.60-8244-31



Example display: current tracklist



① Symbol for next folder up

② Current category

③ Track symbol

④ Current title

► Select the desired track by turning  the controller and press  to confirm.  
The track is played.

► **To switch to the next higher folder:** select the  symbol and press  to confirm.

**i** The  symbol always appears at the top of the track list.

#### Playing back the content of a category or folder

► Select a category or folder by turning  the controller.

► Press  the controller for longer than two seconds.

The content of the category or folder selected is played in accordance with the playback option selected (▷ page 87).

#### Alphabetical track selection

##### iPod®, iPhone® and MP3 player

**i** This function is available for alphabetical categories and folders. It is not available within albums or playlists.

- ▶ Turn **⏪** the controller to select a category, such as **Artists**, and press **⏩** to confirm.  
The available artists are displayed.
- ▶ Press the corresponding number key once or repeatedly to select the initial letter of the desired artist. For example, to select an artist whose name begins with C, press number key **2** ABC three times.  
The available letters are listed at the lower edge of the display.  
After a message, the first entry in the list which matches the letter entered is highlighted.

- i** If no entry matches the entered letter, the first item in the list is the last entry to correspond to a selection.
- i** For iPods®, iPhones® and MP3 players, the quality of the search results is highly dependent on the version and language variant of the software used to populate the device.

If differing sorting rules are defined (such as in iTunes®), the search will be canceled without providing any results.

### Playback options

The following options are available:

- **Normal Track Sequence**  
Normal track sequence: you hear the tracks in their normal order (e.g. numerical or alphabetical).
  - **Random Medium**  
All the tracks on the medium are played in random order.
  - **Random Track List**  
The tracks in the currently active category or folder, including any subfolders, are played in random order.
- ▶ **To select the playback option:** select **Media Interface** from the basic display

by turning **⏪** the controller and press **⏩** to confirm.

The options list appears. The **•** dot indicates the option selected.

- ▶ Select an option and press **⏩** to confirm.

### MP3 player instructions

#### General information

Up to 30,000 tracks per medium are supported.

You can speed up some functions and improve the search results by:

- making sure the names of tracks, albums and artists, for example, are written the same way
- labeling albums featuring various artists as "compilations"

- i** Multiple entries of tracks in playlists are filtered out for some players.

#### Data formats

MP3 and WMA are supported as data formats with fixed and variable bit rates (up to 320 kbit/s).

#### Special considerations when using MP3 players

- Up to eight directory levels with up to 1,000 tracks per directory are supported.
- Do not use USB extension leads or adapters. They can impair functionality.
- i** DRM (Digital Rights Management) protected files are not supported by the Media Interface.

### Audio AUX mode

#### Notes on audio AUX mode



You can connect an external audio source (AUX) to Audio 20 using the jack plug in the

center console. Please consult an authorized Mercedes-Benz Center for further information.





When you connect an external audio source, audio AUX is not selected automatically.

### Activating audio AUX mode

#### Option 1

- ▶ Select **Audio** from the main function bar using the controller (slide ←→ or turn ) and press  to confirm. If AUX mode was the last mode selected, it will now be active.

If another audio source is switched on, you can now switch to audio AUX mode in the audio menu.

- ▶ Slide  the controller to select **Audio** and press  to confirm. The audio menu appears.
- ▶ Turn  the controller to select **Aux** and press  to confirm. The audio AUX menu appears. The medium in the external audio source is played if the source is connected and playback selected.

#### Option 2:

- ▶ Press the **DISC** function button one or more times.

- i** By pressing the function button repeatedly, you can change the operating mode in the following order:
  - Audio CD/MP3 (disc)
  - USB storage device
  - Operation with the Media Interface
  - Bluetooth® audio mode
  - Audio AUX





- i** Please see the respective operating instructions for how to operate the external audio source.

You can select a sound setting specifically for audio AUX mode. See (▶ page 21).

### Adjusting the volume

- i** The volume of external audio sources can vary greatly. In some cases, the volume of the external audio device may be quieter or louder, or the usual maximum possible volume may be lower. On some devices, it is possible to adjust the volume separately. In this case, start at a medium volume and increase it gradually. This enables you to determine whether the system is able to play the music at high volume without distorting it.

You can increase the volume of the external audio sources.

- ▶ Select **VoLume** from the AUX basic menu using the controller (slide ,  or turn ) and press  to confirm. The selection list appears. The **•** dot indicates the option selected.

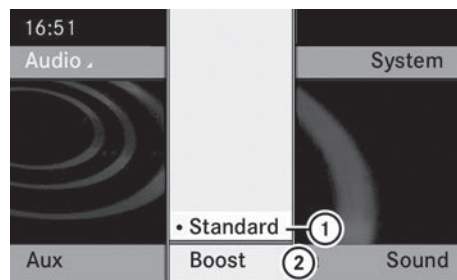

P82.60-8248-31

- ① Default setting
- ② Volume amplification

Audio system features .....	90
General information .....	90
Basic functions .....	91
System settings .....	92
CD/audio DVD and MP3 mode .....	93
Video DVD mode .....	98
AUX mode .....	103



### Audio system features

- i** These Operating Instructions describe all standard and optional equipment available for your audio device at the time of going to print. Country-specific deviations are possible. Please note that your audio equipment may not offer all the features described.

### General information

#### Replacing batteries

Batteries are required for the remote control and for the two sets of cordless headphones.

#### WARNING

Batteries contain toxic and corrosive substances. If batteries are swallowed, it can result in severe health problems. There is a risk of fatal injury.

Keep batteries out of the reach of children. If a battery is swallowed, seek medical attention immediately.

#### Environmental note

Dispose of discharged batteries in an environmentally responsible manner.

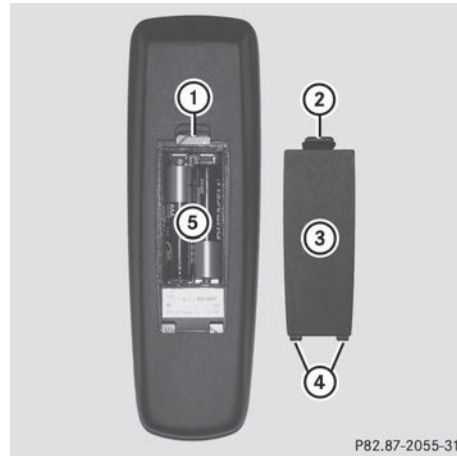

- ① Battery compartment
- ② Catch tab
- ③ Battery compartment cover
- ④ Retaining lugs
- ⑤ Batteries

The remote control contains two AAA, 1.5 V batteries.

- ▶ **To open the battery compartment:**
  - remove battery compartment cover ③ on the back of the remote control.
- ▶ To do so, push catch tab ② downwards and take off battery compartment cover ③.
- ▶ Remove discharged batteries ⑤ from the tray.
- ▶ Insert the new batteries. Observe the polarity markings on the batteries and battery compartment when doing so.
  - Left-hand battery: the positive pole (+) must face upwards.
  - Right-hand battery: the positive pole (+) must face downwards.
- ▶ **To close the battery compartment:**
  - insert battery compartment cover ③ starting with retaining lugs ④ into the battery compartment and allow catch tab ② to engage in place.

### On the cordless headphones

The battery compartment cover is located on the left headphone.



#### ① Battery compartment cover

The cordless headphones contain 2 type AAA, 1.5 V batteries.

- ▶ **To open the battery compartment:** flip battery compartment cover ① upwards. As you do so, hold the left-hand side of the headphones as shown to prevent the batteries from falling out.
  - ▶ Remove the discharged batteries from the tray.
  - ▶ Insert the new batteries. Observe the polarity markings on the batteries and battery compartment when doing so.
    - Left-hand battery: the positive pole (+) must face upwards.
    - Right-hand battery: the positive pole (+) must face downwards.
  - ▶ **To close the battery compartment:** press battery compartment cover downwards until it engages into place. If the batteries have been inserted correctly, the indicator lamp will light up green when the headphones are switched on.
- i** The operating duration of the headphones with a set of batteries is up to 40 hours.

### Basic functions

#### Introduction

The following operating modes are available for the Rear Seat Entertainment System:

- CD/DVD audio and MP3 mode (▷ page 93)
- Video DVD operation (▷ page 93)
- AUX mode (▷ page 103)
  - In AUX mode, you can view external video sources which are connected either to the rear screens (display AUX) or to the CD/DVD drive (drive AUX).

The system settings allow you to adjust screen-related settings, such as the design and the language (▷ page 92).

#### Using headphones



You can use the cordless headphones supplied and/or up to two sets of corded headphones connected to the corresponding jack of the rear-compartment screens (▷ page 24).

#### Adjusting the sound settings







Call up the menu for the respective mode:

- Audio CD (▷ page 94)
  - Audio DVD (▷ page 94)
  - MP3 (▷ page 94)
  - Video DVD (▷ page 99)
  - AUX (▷ page 104)
- ▶ Select **Treble** or **Bass** and press the **OK** button to confirm. An adjustment scale appears.
- ▶ **To make a setting:** press the **▲** or **▼** button until the desired format has been selected.
- ▶ **To confirm your selection:** press the **OK** button.









- ▶ **To change the setting:** use the  or  button to select a language.
- ▶ Press . The Rear Seat Entertainment System activates the selected language.

### Switching the display design





- ▶ Select **Settings** using the  or  button and press  to confirm.
- ▶ Select **Day Mode**, **Night Mode** or **Automatic** using the   buttons and press the  button to confirm. The dot in front of the menu item indicates the currently selected setting.

Design	Explanation
Day Mode	The display is set permanently to day design.
Night Mode	The display is set permanently to night design.
Automatic	The display design changes depending on the vehicle instrument cluster illumination.

### Setting the brightness

- ▶ Select **System Settings** using the  or  button and press  to confirm.
- ▶ Select **Brightness** and confirm with the  button. A scale appears.
- ▶ Adjust the brightness using the   buttons and press the  button to confirm. The brightness bar moves up or down. The picture becomes lighter or darker in accordance with the scale.

### Showing/hiding the picture

- ▶ **To hide the picture:** select **Display Off** in the system menu using the   buttons on the remote control and press the  button to confirm. The picture is hidden.
- ▶ **To show the picture:** press the  button on the remote control.

### CD/audio DVD and MP3 mode

#### Important safety notes

##### **WARNING**

The CD/DVD drive is a class 1 laser product. If you open the CD/DVD drive housing, you could be exposed to invisible laser radiation. This laser radiation could damage your retina. There is a risk of injury.

Never open the housing. Always have maintenance and repair work carried out at a qualified specialist workshop.

#### General notes

You will find information on the following topics in the Audio section:

- notes on CDs/DVDs (▷ page 75)
- notes on MP3 mode (▷ page 75)
- notes on copyright (▷ page 76)

#### Inserting a CD/DVD

-  The CD/DVD drive is located in the center behind the front seats.

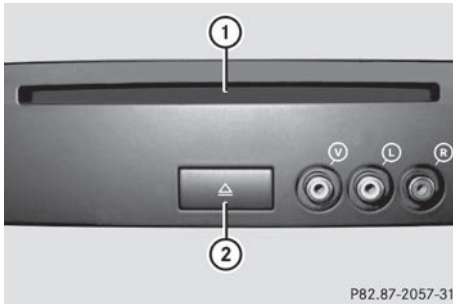

P82.87-2057-31

- ① Disc slot
- ② Eject button

The CD/DVD drive holds one disc. If there is already a disc inserted, this must be ejected before another is inserted.

- ▶ Insert a disc into the disc slot.  
The printed side of the disc must face upwards. If neither side of the disc is printed, the side you wish to play must face downwards.  
The CD/DVD drive draws the disc in.

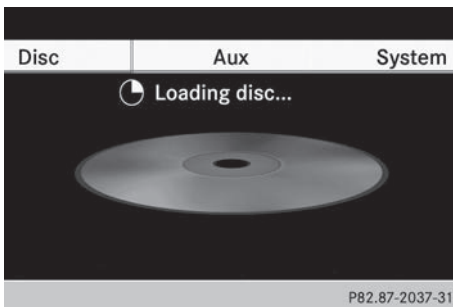

P82.87-2037-31

The CD/DVD drive plays the disc:

- if it has been inserted correctly and is a permissible disc, and
- if you have switched to disc mode (audio CD, audio DVD and MP3 mode) (> page 94)

Data on an MP3 CD first needs to be loaded by the drive. Loading may take some time, depending on the number of folders and tracks.

### Removing a CD/DVD

- ▶ Press eject button ②.  
The drive ejects the disc.
- ▶ Take the disc out of the slot.  
If you do not take the disc out of the slot, the drive will draw it in again automatically after a short while.

### Switching to audio CD, audio DVD or MP3 mode

#### Introduction

- ▶ Insert a CD/DVD (> page 93).  
The Rear Seat Entertainment System loads the inserted disc.
- ▶ Select **Disc** with the remote control and confirm with **OK**.
- ▶ The corresponding mode is activated. The Rear Seat Entertainment System plays the disc.

#### Example display: audio CD mode

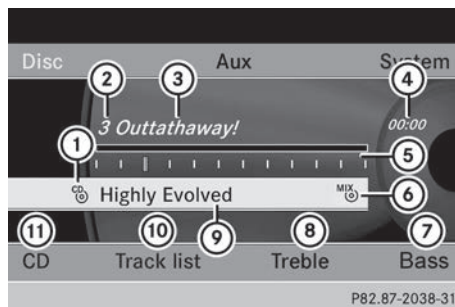

P82.87-2038-31

- ① Data medium type
- ② Track number
- ③ Track name (only if stored on the disc as CD text)
- ④ Track time
- ⑤ Graphic time and track display
- ⑥ Current playback settings (no symbol for "Normal track sequence")
- ⑦ To set the bass
- ⑧ To set the treble

- ⑨ Disc name (only if stored on the disc as CD text)
- ⑩ To call up the track list
- ⑪ To select playback options

### Example display: audio DVD mode

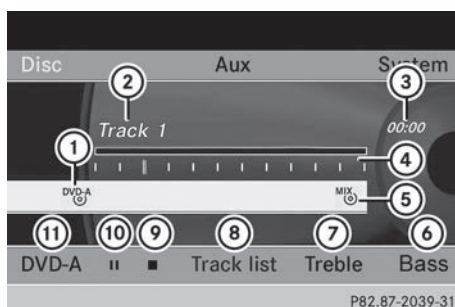

- ① Data medium type <sup>DVD-A</sup>
- ② Track number
- ③ Track time
- ④ Graphic time and track display
- ⑤ Current playback settings (no symbol for "Normal track sequence")
- ⑥ To set the bass
- ⑦ To set the treble
- ⑧ To call up the track list
- ⑨ Stop function
- ⑩ Pause function
- ⑪ To select playback options

### Example display: MP3 mode

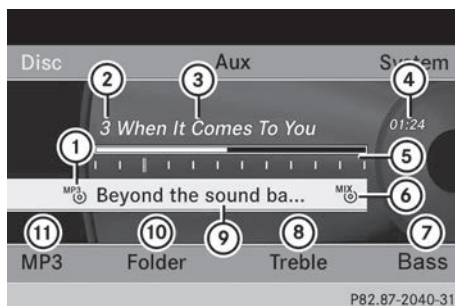

- ① Data medium type <sup>MP3</sup>
- ② Track number

- ③ Track name
  - ④ Track time
  - ⑤ Graphic time and track display
  - ⑥ Current playback settings (no symbol for "Normal track sequence")
  - ⑦ To set the bass
  - ⑧ To set the treble
  - ⑨ Disc name or current folder
  - ⑩ To call up the folder list
  - ⑪ To select playback options, switch track information on or off
- ❗ Variable bit rates in MP3 tracks can result in the elapsed time shown being different from the actual elapsed time.

### Selecting a track

#### Selecting by skipping to a track

- ▶ **To skip forwards or backwards to a track:** press the ◀ or ▶ button when the display/selection window is active.

or

- ▶ Press the ⏮ or ⏭ button.

**Skip forwards:** you hear the next track.

**Skip back:** the current track is restarted if it has been playing for longer than approximately 10 seconds. If it has been playing for less time, the previous track is played.

#### Selecting by track list

- ❗ In audio CD mode, the track list contains all tracks on the disc currently playing.
- In audio DVD mode, the track list contains all tracks in the currently active group; see "Setting the audio format" (▷ page 97).
- In MP3 mode, the track list shows all tracks in the currently active folder as well as the folder structure, allowing you to select any track on the MP3 CD.

- ▶ Select **Track List** (audio CD/audio DVD mode) or **Folder** (MP3 mode).

or

- ▶ Press the **OK** button when the display/selection window is active. The track list appears. The ● dot indicates the current track.

- ▶ **To select a track:** press the **▲** or **▼** button.

- ▶ Press the **OK** button.

### Making a selection by entering the track number directly

- ▶ Press the **\*** button. The track entry display appears.

Example: track 2

- ▶ Press the **2** number key.

Example: track 12

- ▶ Press the corresponding number keys in rapid succession.

- ▶ **i** It is not possible to enter numbers that exceed the number of tracks on the CD or in the currently active folder.

- ▶ Wait for approximately three seconds after making an entry. You will hear the track which has been entered. The corresponding basic menu then reappears.

### Fast forwarding/rewinding

- ▶ With the display/selection window active, press the **◀** or **▶** button repeatedly until you reach the desired position.

or

- ▶ Press and hold the **◀◀** or **▶▶** button until the desired position is reached.

### Selecting a folder

- ▶ **i** This function is only available in MP3 mode.

- ▶ In MP3 mode, select **Folder** and confirm with **OK**.

or

- ▶ Press the **OK** button when the display/selection window is active. The folder content appears.



- ① Folder selection symbol

- ② Current folder name

- ③ Track symbol

- ▶ To switch to the next folder up: select icon ①.

The display shows the next folder up.



- ① Folder selection symbol









- ② Folder symbol

- ▶ Select a folder using the **▲** or **▼** button and press the **OK** button to confirm. You will see the tracks in the folder.











- ▶ Select a track using the **▲** or **▼** button and press the **OK** button to confirm. The track is played and the corresponding folder is now the active folder.



### Pause function

- i** This function is only available in audio DVD mode.
- ▶ **To pause playback:** select  and press  to confirm. The  display changes to .
- ▶ **To continue playback:** select  and press  to confirm. The  display changes to .











### Stop function

- i** This function is only available in audio DVD mode.
- ▶ **To interrupt playback:** select  and press  to confirm. The  display changes to .
- ▶ **To continue playback:** select  and press  to confirm. Playback continues from the point where it was interrupted.
- ▶ **To stop playback:** while playback is interrupted, select  again and press  to confirm. Playback stops and returns to the beginning of the DVD.  is highlighted.
- ▶ **To restart playback:** select  and press  to confirm. Playback starts from the beginning of the DVD.

### Setting the audio format

- i** You can only set the audio format in audio DVD mode. The number of audio formats available depends on the DVD. The content of an audio DVD is called an "album", and this can be divided into up to nine groups. A group can contain music in different sound qualities (stereo and multichannel formats, for example), or bonus tracks. Each group can contain up to 99 tracks. If an audio DVD only contains one audio





format, the **Group** menu item cannot be selected.

- ▶ Press the  or  button to select **DVD-A** and confirm with the  button.
- ▶ Press the  or  button to select **Group** and confirm with the  button. The list of available audio formats appears. The  dot indicates the format currently selected.
- ▶ **To change a setting:** press the  or  button.
- ▶ Press the  button.
- ▶ **To exit the menu:** press the  button.

### Playback options

#### Introduction

The following options are available:

- **Normal Track Sequence**
- **Random Tracks**
- **Random Folder** (only in MP3 mode)
- ▶ **To select an option:** select **CD** or **DVD-A** or **MP3**. The options list appears. The  dot indicates the option currently selected.
- ▶ Press the  or  button to select a different option.
- ▶ Press the  button. The option is switched on. For all options except **Normal Track Sequence**, you will see a corresponding display in the display/selection window.
- i** If you change the disc, the **Normal Track Sequence** option is activated automatically. If an option is selected, it remains selected after the Rear Seat Entertainment System is switched on or off.



### Explanation of the playback options

- **Normal Track Sequence**

In CD/audio DVD mode, you hear all the tracks in their normal sequence (e.g. track 1, 2, 3 etc.).

In MP3 mode, the track order is determined by the order in which the tracks are written to the MP3 data carrier when it is created. Alphabetical order is the most common.

Once all the tracks in a folder have been played, the tracks in the next folder are played.

- **Random Tracks**

The tracks are played in a random order (e.g. track 3, 8, 5, etc.).

- **Random Folder** (MP3 mode only)

This option is limited to the tracks in the currently active folder. You hear the tracks in random order.

### Switching track information on/off (MP3 mode only)

When the function is activated, the folder and track names are displayed.

When the function is deactivated, the disc and file names are displayed.

- ▶ Select **Display Track Information**.  
The function is switched on  or off , depending on the previous status.

### Video DVD mode

#### Important safety notes

#### WARNING

The CD/DVD drive is a class 1 laser product. If you open the CD/DVD drive housing, you could be exposed to invisible laser radiation. This laser radiation could damage your retina. There is a risk of injury.

Never open the housing. Always have maintenance and repair work carried out at a qualified specialist workshop.

### Notes on discs

Notes about CDs/DVDs can be found here ([▷ page 75](#)).

### DVD playback conditions

There are video DVDs available on the market which do not conform to the current standards.

Such DVDs may have picture, sound or other playback problems.

The Rear Seat Entertainment System can play back video DVDs produced according to the following standards:

- Region code 2 (for Europe) or region code 0 (no region code)
- PAL or NTSC standard

You will generally find the relevant details either on the DVD itself or on the DVD case.

**i** If you insert a video DVD with a different region code, you will see a message to this effect.

**i** The Rear Seat Entertainment System is set to region code 2 at the factory. This setting can be changed at an authorized Mercedes-Benz Center. This will allow you to play video DVDs with a different region code, provided that they are produced in accordance with the PAL or NTSC TV standard.

Playback problems may occur when playing copied discs. There is a large variety of discs, DVD authoring software, writing software and writers available. This variety means that there is no guarantee that the Rear Seat Entertainment System will be able to play video DVDs that you have copied yourself.

### Function restrictions

Depending on the DVD, it is possible that certain functions or actions described in this section will be temporarily blocked or may not

function at all. As soon as you try to activate these functions or actions, you will see the  symbol in the display.

### Inserting and removing DVDs

- ▶ Proceed as described in the "CD/audio DVD and MP3 mode" (> page 93) section.

### Switching to video DVD mode

- ▶ Insert a video DVD.  
The Rear Seat Entertainment System loads the disc.
- ▶ Select **Disc** with the remote control and confirm with .  
You switch to video DVD mode.





#### The video DVD meets the playback

**criteria:** either the film will begin playing automatically or the DVD menu stored on the DVD will appear. If the DVD menu appears, you must start the film manually.

- ▶ Select the corresponding menu item in the DVD menu (> page 101).

-  If disc mode was selected previously, the Rear Seat Entertainment System automatically plays a disc once you have inserted it.

### Showing/hiding the control menu

- ▶ **To show:** press the  or  button.
  - ▶ **To hide:** press the  or  button.
- or
- ▶ Wait about eight seconds.

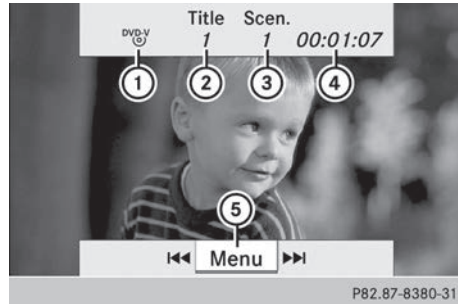

Navigation menu

- ① Type of data medium
- ② Current title
- ③ Current scene
- ④ Track time
- ⑤ Shows the menu system

### Showing/hiding the menu

- ▶ **To show:** press the  button.

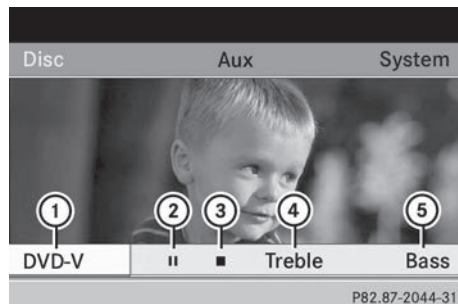

or

- ▶ When the navigation menu is shown, select **Menu**.





Menu system







- ① Video DVD options
- ② Pause function
- ③ Stop function
- ④ To set the treble
- ⑤ To set the bass

- ▶ **To hide:** press the  button, select **Full Screen** and press the  button to confirm.











### Fast forwarding/rewinding

- ▶ Press and hold the  or  button until the desired position is reached. You see the control menu.

### Pause function

- ▶ Display the menu system (▷ page 99).
- ▶ **To pause playback:** select  and press the  button to confirm. The  display changes to .
- ▶ **To continue playback:** select  and press the  button to confirm. The menu system is hidden.

### Stop function



- ▶ Display the menu system (▷ page 99).
- ▶ **To interrupt playback:** select  and press the  button to confirm. The display  switches to . The video image is hidden.
- ▶ **To continue playback:** select  and press the  button to confirm. Playback continues from the point where it was interrupted. The menu system is hidden.
- ▶ **To stop playback:** while playback is interrupted, select  again and press the  button to confirm. Playback stops and returns to the beginning of the DVD.  is highlighted.
- ▶ **To restart playback:** select  and press the  button to confirm. Playback starts from the beginning of the DVD.

### Selecting a scene/chapter



#### Introduction

If the film is divided into scenes or chapters, you can select them directly while the film is

running, or skip forwards step-by-step. Some DVDs do not permit this at certain points (e.g. during the opening credits).



- ▶ **To skip forwards or backwards:** press the  or  button.

or









- ▶ Press the  or  button. The navigation menu (▷ page 99) appears for approximately eight seconds.

### Selecting a scene/chapter directly

Example: scene/chapter 5

- ▶ Press the  button while the film is playing.
- ▶ Press the corresponding number key, such as .

or

- ▶ Display the menu system (▷ page 99).
- ▶ Select **DVD-V** using the  or  button and confirm with the  button.
- ▶ Select **DVD Functions** using the  or  button and confirm with the  button.
- ▶ Select **Scene Selection** from the menu and press the  button to confirm.
- ▶ Select number **5** and confirm with the  button.

In both cases, playback will begin from the fifth scene/chapter after a brief pause.

- ▶ **i** It may also be possible to select the scene/chapter from within the menu stored on the DVD.

### Selecting a film/title

#### Introduction

If the DVD contains several films, these can be selected directly. A film can be selected either when the DVD is being played back or when it is stopped.

- ▶ Display the menu system (▷ page 99).
- ▶ Select **DVD-V** using the ◀ or ▶ button and confirm with the **OK** button.
- ▶ Select **DVD Functions** using the ▲ or ▼ button and confirm with the **OK** button.

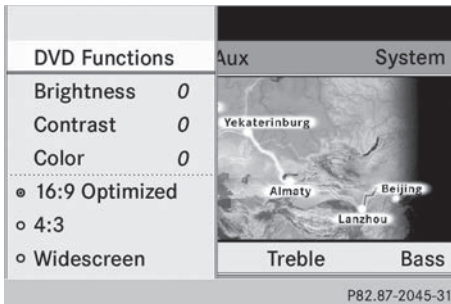

- ▶ Select **Title** from the menu.
- ▶ **To call up the selection list:** press the **OK** button.
- ▶ Select a film/title.

### Selecting a film/track directly

Example: selecting film 2

- ▶ Press the **2** button.  
After a brief pause, the second film is played.
- i** The film can also be selected from the menu on the DVD itself.

### Picture settings

#### Adjusting the brightness, contrast or color

- ▶ Display the menu system (▷ page 99).
- ▶ Select **DVD-V** using the ◀ or ▶ button and confirm with the **OK** button.
- ▶ Select **Brightness** or **Contrast** or **Color** with the ▲ or ▼ button and confirm with the **OK** button.

- ▶ **To change a setting:** press and hold the ▲ or ▼ button until the desired setting has been reached.
- ▶ **To store the setting:** press the **OK** button.

### Changing the picture format

- ▶ Display the menu system if necessary (▷ page 99).
- ▶ Select **DVD-V** using the ◀ or ▶ button and confirm with the **OK** button.  
The DVD-V menu appears. The ● icon in front of one of these menu items: **16:9 Optimized**, **4:3** or **Widescreen** indicates the currently selected format.
- ▶ **To change the format:** press and hold the ▲ or ▼ button until the desired format is selected.
- ▶ **To store the setting:** press the **OK** button.

### DVD menu





#### Calling up the DVD menu

The DVD menu is the menu stored on the DVD itself. It is structured in various ways according to the individual DVD and permits certain actions and settings.

In the case of multi-language DVDs, for example, you can change the DVD language in the DVD menu.

- ▶ Display the menu system (▷ page 99).
- ▶ Select **DVD-V** using the ◀ or ▶ button and confirm with the **OK** button.
- ▶ Select **DVD Functions** using the ▲ or ▼ button and confirm with the **OK** button.
- ▶ Select **Menu** and confirm with the **OK** button.  
The DVD menu appears.

### Selecting menu items in the DVD menu

- ▶ Press the , ,  or  button.
- ▶ **To confirm your selection:** press the  button.  
The selection menu appears.
- i** Menu items which cannot be selected are grayed out.



- ▶ Confirm **Select**.  
The Rear Seat Entertainment System carries out the action or displays a submenu for the item selected in the DVD menu.
- ▶ Make a selection from the further options, if necessary.  
The Rear Seat Entertainment System then switches back to the DVD menu.
- i** Depending on the DVD, the menu items: **Back (to the movie)**, **Play**, **Stop**, **◀◀**, **▶▶** or **Go Up** may not function or not function at certain points in the DVD menu. To indicate this, the  symbol appears in the display.

### Stopping a film or skipping to the beginning or end of a scene

- ▶ Select any menu item from the DVD menu.  
The selection menu appears.
- ▶ **To stop a film:** select **Stop** from the menu.
- ▶ **To skip to the end of a scene:** select **▶▶** from the menu.
- ▶ **To skip to the beginning of a scene:** select **◀◀** from the menu.

### Moving up one level in the DVD menu









- ▶ Press the  back button.
- or
- ▶ Select the corresponding menu item from the DVD menu.
- or
- ▶ Select any menu item from the DVD menu.
- ▶ Select the **Go Up** menu item from the menu.











### Back to the movie

- ▶ Press the  back button repeatedly until you see the film.
- or
- ▶ Select the corresponding menu item from the DVD menu.
- or
- ▶ Select any menu item from the DVD menu.
- ▶ Select the **Back (to movie)** menu item from the selection menu.

### Setting the language and audio format













This function is not available on all DVDs. If it is available, you can set the audio language or the audio format. The number of settings is determined by the DVD content. It may also be possible to access the settings from the DVD menu.

- ▶ Display the menu system (> page 99).
- ▶ Select **DVD-V** using the  or  button and confirm with the  button.
- ▶ Select **DVD Functions** using the  or  button and confirm with the  button.
- ▶ Select **Audio Language** and press the  button to confirm.  
A selection menu appears after a short while. The  dot in front of an entry indicates the currently selected language.

- ▶ **To change a setting:** press and hold the  or  button until the desired setting has been reached.
- ▶ **To store the setting:** press the  button.
- ▶ **To exit the menu:** press the  or  button.
- ▶ **To select an action:** press the , ,  or  button.
- ▶ **To trigger an action:** press the  button. A menu appears and the first entry, **Select**, is highlighted.
- ▶ Press the  button.

### Subtitles and camera angle

These functions are not available on all DVDs. The number of subtitle languages and camera angles available depends on the content of the DVD. It may also be possible to access the settings from the DVD menu.

- ▶ Display the menu system (▷ page 99).
- ▶ Select **DVD-V** using the  or  button and confirm with the  button.
- ▶ Select **DVD Functions** using the  or  button and confirm with the  button.
- ▶ Select **Subtitles** or **Camera Angle** and confirm with the  button.  
In both cases, a selection menu appears after a short while. The ● dot in front of an entry indicates the current setting.
- ▶ **To change a setting:** press and hold the  or  button until the desired setting has been reached.
- ▶ **To store the setting:** press the  button.
- ▶ **To exit the menu:** press the  or  button.

### Interactive content

DVDs can also contain interactive content (e.g. a video game). In a video game, you may be able to influence events by selecting and triggering actions. The type and number of actions depend on the DVD.

### AUX mode

#### Introduction

You can connect one external video source to each of the displays of the Rear Seat Entertainment System (AUX display) and also one external video source to the rear-compartment CD/DVD drive (AUX drive) with a sound and video signal.

Please see the corresponding operating instructions for information on how to operate the external video source.

For further details about external video sources, please consult an authorized Mercedes-Benz Center.

#### Connecting AUX equipment

##### AUX drive

The AUX drive jacks are located on the CD/DVD drive next to the CD/DVD eject button (▷ page 26).

##### Displaying AUX



The AUX display jacks are on the side of the screen (▷ page 24).

##### Audio and video connection

- ▶ Insert the audio plugs for the left and right signals into the corresponding **L** and **R** jacks.
- ▶ Insert the video plug into the **V** jack.

### Activating AUX mode



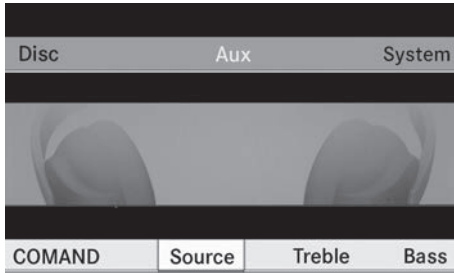

#### AUX drive

- ▶ Select **Aux** using the  or  button and confirm with the  button. The AUX menu appears.









P82.60-7389-31

AUX menu



- ▶ Select **Source** and confirm with the  button.
- ▶ Select the **Disc Drive Aux** with the  or  button and confirm with the  button. You will hear and see the content of the video source if it is connected to the CD/DVD drive and switched to playback. If no video image is available from the AUX source connected, you will see an audio menu.

#### Displaying AUX





- ▶ Select the screen to which an external video source is connected for the remote control.
- ▶ Select **Aux** using the  or  button and confirm with the  button.
- ▶ Select **Source** and confirm with the  button.
- ▶ Select **Display Aux** with the  or  button and confirm with the  button. You will see and hear the content of the video source if it is switched to playback. If no video image is available from the AUX

source connected, you will see an audio menu.

### Adjusting the brightness, contrast or color

- ▶ Select **Display Aux** or **Disc Drive Aux** in the Aux menu.
- ▶ Select **Brightness**, **Contrast** or **Color**. An adjustment scale appears.
- ▶ **To make a setting:** press the  or  button.
- ▶ **To confirm your selection:** press the  button.

### Changing the picture format

- ▶ Select **Display Aux** or **Disc Drive Aux** in the Aux menu and confirm with the  button. The  icon in front of the **16:9 Optimized**, **4:3** or **Widescreen** menu item indicates the format currently set.
- ▶ **To change the format:** press and hold the  or  button until the desired format is selected.
- ▶ **To store a setting:** press .



1725843381

Order no. 6515 6976 13 Part no. 172 584 33 81 Edition B 2013